

 Mensch und Maschine at a glance

All amounts in million EUR (unless stated otherwise)	2015	2016	2017	2018	2019	2020	2021	2022	2023	2024	2025
Revenue	160.4	167.1 +4.2%	160.9 -3.7%	185.4 +15%	245.9 +33%	244.0 -0.8%	266.2 +9.1%	320.5 +20%	322.3 +0.6%	325.84 +1.1%	238.59 -27%
Germany	74.7 47%	74.9 44.8%	75.9 47.2%	83.3 44.9%	113.0 45.9%	113.1 46.3%	113.9 42.8%	134.2 41.9%	133.5 41.4%	138.46 42.5%	100.60 42.2%
International	85.7 53%	92.2 55.2%	85.0 52.8%	102.1 55.1%	132.9 54.1%	130.9 53.7%	152.3 57.2%	186.3 58.1%	188.8 58.6%	187.38 57.5%	137.99 57.8%
Gross profit	84.5	91.4 +8.2%	94.8 +3.7%	103.9 +9.6%	127.9 +23%	128.0 +0.1%	138.4 +8.2%	161.1 +16%	168.5 +4.6%	174.59 +3.6%	181.88 +4.2%
M+M Software	39.6 47%	44.7 48.9%	48.9 51.6%	54.3 52.3%	69.7 54.5%	68.9 53.8%	76.1 55.0%	87.5 54.3%	94.9 56.3%	99.03 56.7%	102.74 56.5%
M+M Digitization	44.9 53%	46.7 51.1%	45.9 48.4%	49.6 47.7%	58.2 45.5%	59.1 46.2%	62.3 45.0%	73.6 45.7%	73.6 43.7%	75.56 43.3%	79.14 43.5%
Operating profit EBITDA	12.8	15.8 +23%	18.0 +14%	22.7 +26%	36.5 +61%*	40.3 +10%	44.4 +10%	52.7 +19%	56.6 +7.5%	56.74 +0.2%	60.42 +6.5%
EBITDA return from revenue	8.0%	9.4%	11.2%	12.3%	14.9%	16.5%	16.7%	16.4%	17.6%	17.4%	25.3%
Operating profit EBIT	8.5	12.5 +47%	15.2 +22%	19.7 +29%	27.2 +38%	31.0 +14%	34.7 +12%	42.6 +23%	46.8 +10%	46.47 -0.8%	49.11 +5.7%
EBIT return from revenue	5.3%	7.5%	9.5%	10.6%	11.1%	12.7%	13.0%	13.3%	14.5%	14.3%	20.6%
Net profit after minorities	3.9	6.6 +70%	8.5 +30%	11.7 +37%	16.7 +43%	18.7 +12%	21.3 +14%	26.0 +22%	28.9 +11%	30.49 +5.6%	31.81 +4.3%
Net return from revenue	2.4%	3.9%	5.3%	6.3%	6.8%	7.7%	8.0%	8.1%	9.0%	9.4%	13.3%
per share in EUR	0.24	0.40	0.525	0.715	0.99	1.115	1.26	1.55	1.72	1.80	1.91
Operativer Cashflow	14.7	14.6 -0.1%	15.2 +4.0%	15.2 +0.2%	26.3 +73%*	33.7 +28%	36.9 +9.4%	39.0 +5.8%	50.6 +30%	62.32 +23%	16.58 -73%
per share in EUR	0.91	0.90	0.935	0.93	1.57	2.01	2.18	2.33	3.02	3.69	0.995
Dividend in EUR	0.25	0.35 +40%	0.50 +43%	0.65 +30%	0.85 +31%	1.00 +18%	1.20 +20%	1.40 +17%	1.65 +18%	1.85 +12%	2.00 +8.1%
Total assets	102.5	100.5 -2%	101.8 +1%	106.1 +4%	159.5 +50%*	154.7 -3%	160.8 +4%	187.5 +17%	187.2 -0%	211.89 +13%	201.16 -5%
Shareholders' equity	39.2	39.6 +1%	40.6 +2%	43.9 +8%	51.3 +17%	73.5 +43%	80.2 +9%	92.8 +16%	85.7 -7.6%	99.76 +16%	84.76 -19%
Equity ratio	38.6%	40.4%	43.1%	48.3%	46.1%	51.8%	57.7%	45.7%	53.3%	49.5%	42.1%
# Shares in million	16.127	16.306 +1.1%	16.281 -0.2%	16.351 +0.4%	16.820 +2.9%	16.783 -0.2%	16.897 +0.7%	16.769 -0.8%	16.773 +0.0%	16.908 +0.8%	16.663 -1.4%
# Headcount (FTE)	731	759 +3.8%	784 +3.3%	821 +4.7%	946 +15%	948 +0.2%	979 +3.3%	1.031 +5.3%	1.056 +2.4%	1.095 +3.7%	1.127 +2.9%

* COMPARISON 2019/18 DISTORTED BY FIRST TIME APPLICATION OF IFRS16

 Content

Management report	2
Course of business 2025	22
Statement of income	27
Balance sheet	28
Statement of cash flows	29
Development of shareholders' equity	29
Notes	30
Segment reporting	30
Auditor's report	65
Administrative Board report	70
Addresses	72

Dear reader,

In 2025, as in the previous year, M+M has laid a very solid foundation for the future with high investments in internal IT, the transition to the new Autodesk commission model, and the development of our own software products.

Despite the associated burdens, we achieved new record results, allowing us to increase the dividend again by +8.1% to 200 Cents.

Sustainably profitable strategy ...

In the ten years since 2015, M+M generated a highly disproportionate net profit increase of +23% per year from a gross profit increase of +8.0% p.a. through consistent cost discipline.

The dividend growth was also strong at +23% per year – increasing tenfold from 20 Cents to 200 Cents in the eleven years since 2014. By the way: Anyone who has invested a fixed amount in M+M shares every month since our IPO in 1997 has now received almost 1.5 times their initial investment in dividends alone.

... will be continued in the future

Also for the future, it is M+M management's clear goal to grow sustainably and profitably by consequent continuation of this strategy and to reward our shareholders with a decent dividend.

Profit growth & full dividend distribution

Our medium-term goal is therefore to double our earnings in 5 years – while maintaining the full dividend policy that we can afford because we book the lion's share of our software development as operating expenses and do not capitalize it.

Motto: Digitalization is sustainability

Since our business model is consistently based on process optimization and the resulting resource savings for our customers, we operate not only economically but also ecologically sustainably – hence our company motto 'Digitalization is Sustainability' - please read more about this topic on pages 16/17.

Wessling, March 2026

Your M+M Group Management Board

2025 at a glance

- Group sales: EUR 238.59 mln / -27%
 - M+M Software: EUR 114.47 mln / +4.7%
 - Digitization: EUR 124.11 mln / -43% (transition from resale to commission)
- Record gross profit: EUR 181.88 mln / +4.2%
 - M+M Software: EUR 102.74 mln / +3.7%
 - Digitization: EUR 79.14 mln / +4.7%
- Operating profit EBIT: EUR 49.11 mln / +5.7%
 - M+M Software: EUR 32.40 mln / +5.9%
 - Digitization: EUR 16.71 mln / +5.2%
- Record net profit: EUR 31.81 mln / +4.3%
 - Per share: 191 Cents (PY: 180 / +5.9%)
- Operating Cashflow: EUR 16.58 mln / -73%
 - Per share: 99.5 Cents (PY: 369)
- Dividend proposal: 200 Cents (PY: 185)
- Headcount Dec 31, 2025: 1.192 / +1.1%
 - Full time equivalent 2025: 1.127 / +2.9%

Adi Drotleff
Founder / Chairman



Markus Pech
Group CFO



Volker Nesenhoener
CAD/CAM Software



Marcus Hoellrich
Digitization Segment



Wolfgang Huber
Manufacturing / CAE



Roman Wagener
Architecture / BIM



Group overview 2025

Enterprise and market position

Mensch und Maschine Software SE (M+M) is a leading provider of technical software and digitization solutions in the CAD/CAM/CAE (Computer Aided Design, Manufacturing & Engineering) and PDM/PLM (Product Data / Lifecycle Management) and BIM (Building Information Modeling / Management) areas.

42 years at market, 29 years public

M+M was founded in 1984, and quickly developed into the leading European partner of today's CAD world market leader Autodesk. In 1997 M+M's IPO took place as one of the first issuers on the 'Neuer Markt'.

The M+M business model has since been going through a transition process which strengthened M+M's proprietary part and significantly improved scalability.

Two Segments: Software & Digitization

The M+M business model is today based on the segments Software and Digitization (former name: VAR Business).

The M+M Software segment is developing standard software for the areas CAD/CAM, BIM/Engineering, Garden/Landscaping & CAE. Our CAD/CAM and BIM/Engineering software is marketed and sold globally to more than 70 countries, through our own subsidiaries, distributing partners and by export.

The Digitization segment develops tailor-made software solutions for customers in D/A/CH and several other European countries.

The segment's added value primarily comes from customer-specific adaptations, training and the Autodesk business, which actually contributes less than 25% to group gross profit (in 2001 this had been more than 75%).

The two segment M+M business model: The Digitization segment with its broad customer base drives the group's market share, while M+M Software is contributing more to gross profit and profitability.

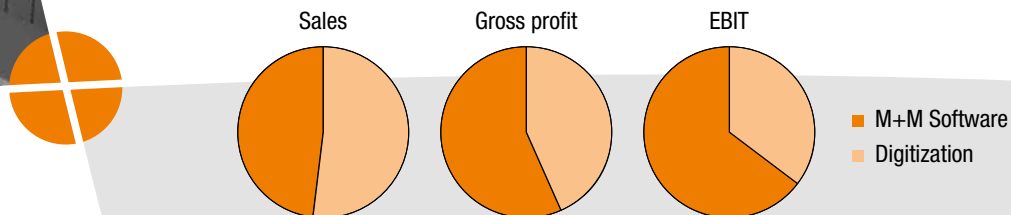
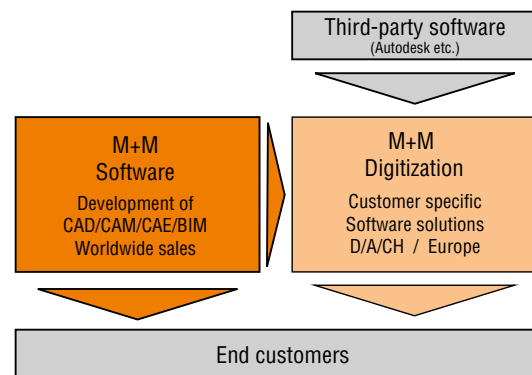

Global sales with D/A/CH focus

In 2025 the lion's share of EUR 238.6 mln sales was contributed by the D/A/CH region with 55.4% (42.2% Germany plus 13.2% Switzerland/Austria), while 31.6% came from other European markets.

EUR 31.1 mln or 13.1% were achieved in Asia, North and South America, Africa and Australia with M+M's self-developed CAM and BIM/Engineering Software products - a EUR 1.9 mln / +6.4% surplus.

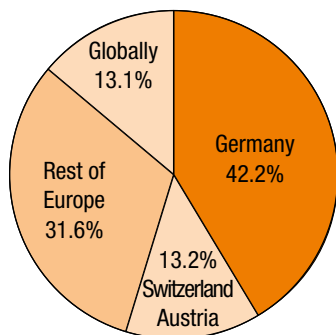

With around 75 locations in 22 countries (colored darker here), the M+M group is one of the leading providers of technical software and digitization. Geographically, the D/A/CH region and Europe dominate sales, but in 2025 a noticeable EUR 31.1 mln or 13.1% were achieved globally, as M+M's self-developed CAM and BIM/Engineering Software is sold to over 70 countries.

Large customer and installation base

Altogether, Mensch und Maschine's active installed base consists of far more than 100,000 CAD/CAM/CAE/PDM/PLM/BIM seats at over 30,000 end customer sites of all size categories - from small engineer's or architect's offices up to international large-scale enterprises.

M+M operates predominantly in the B2B (business-to-business) sector and only marginally in B2C (business-to-consumer).

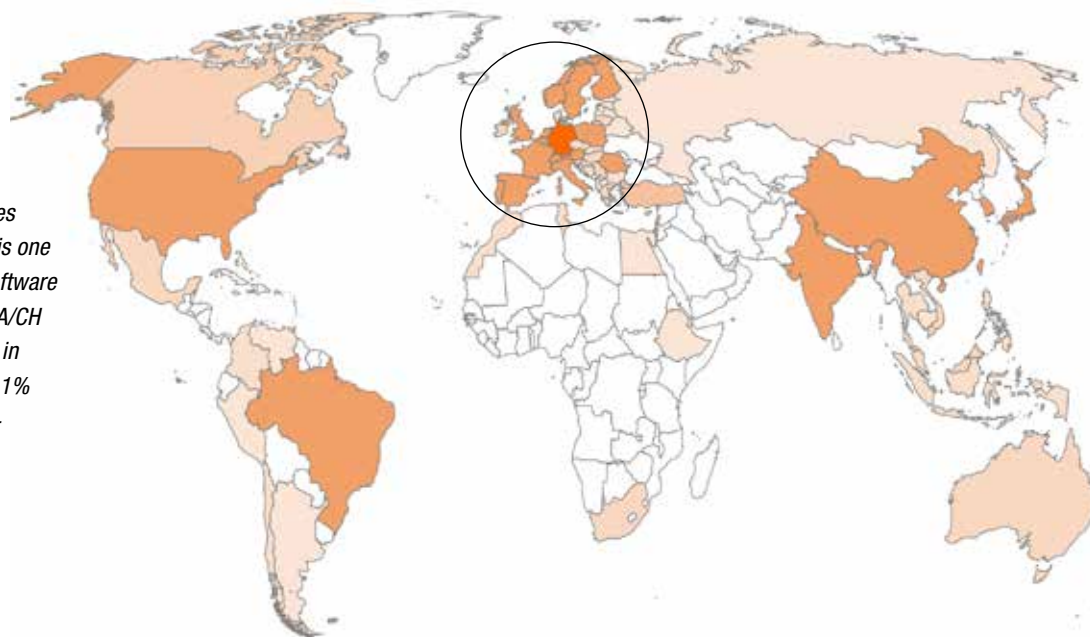

The M+M Portfolio:

Digital twins by CAD/CAM/CAE/BIM/PDM/PLM

The extensive M+M portfolio consists of various digital twins, each of which maps complex 3D structures including associated metadata, across industries and segments for the areas of manufacturing, architecture/ engineering/construction and infrastructure.

Some examples of such digital twins by M+M:

With the *hyperMILL* CAM software, the entire machining process can be simulated and optimized in 'virtual machine', which contributes significantly to the rapid amortization of our customers' very expensive precision machine tools (pages 6/7 and cover).

BIM - Building Information Modeling/Management: All disciplines of a building in 3D, including masses and cost dimensions as well as project timeline. With BIM Ready, BIM Booster and software solutions for Civil Engineering and Gardening/Landscaping/Earthworks, M+M is among the pioneers in this area (pages 8/9/10/12/13).

BIM for Infrastructure management: M+M MapEdit connects geo and land register data with other data sources to digital city or factory twins, enabling any type of inquiry by internal or external users easily via the web (page 14).

And last but not least, many of M+M's manufacturing customers use PDM Booster, eXs or customX for digital twins in data management, CAE / plant construction or variant design, in order to significantly increase their productivity (pages 11-14).

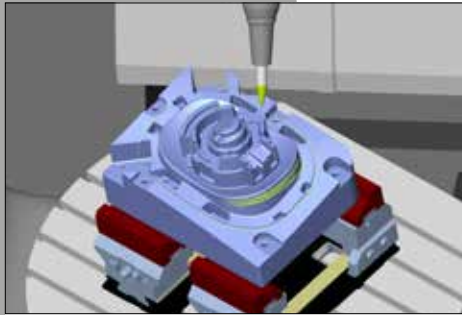
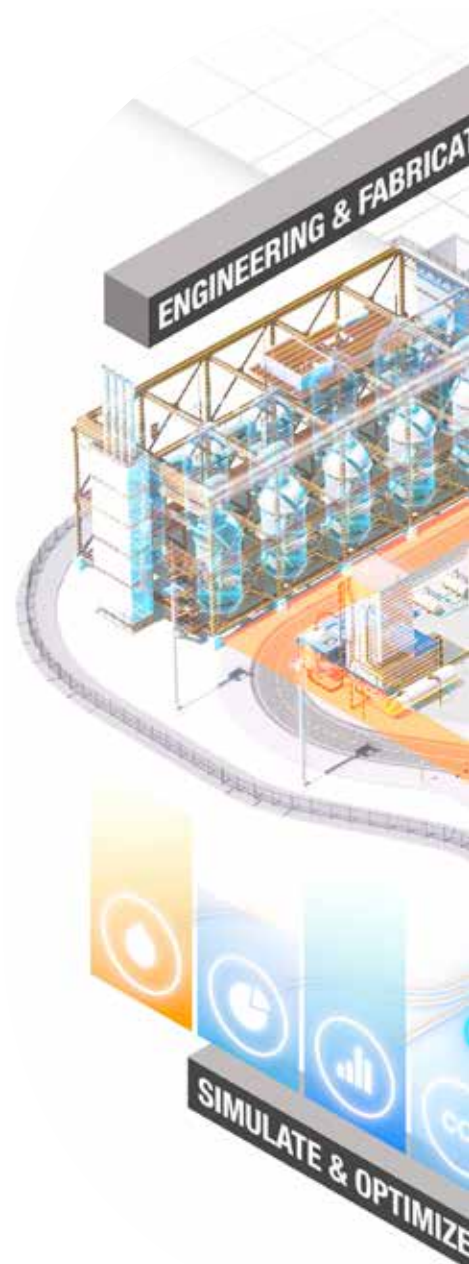

Virtual Machining in CAM: M+M's hyperMILL



BIM - Building Information Modeling/Management

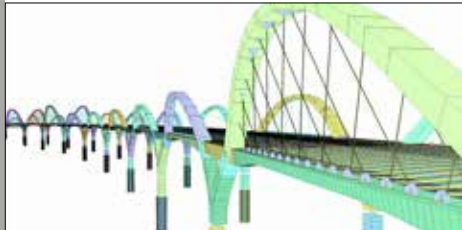

BIM in Civil Engineering: M+M SOFiSTiK Software



BIM for Infrastructure-Management: M+M MapEdit



Manufacturing: M+M PDM Booster, CAE/eXs, customX

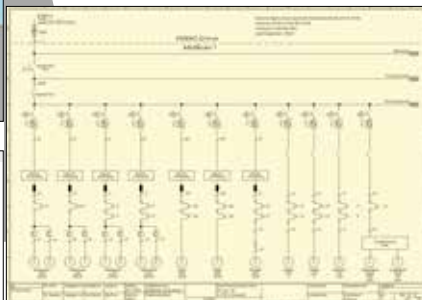

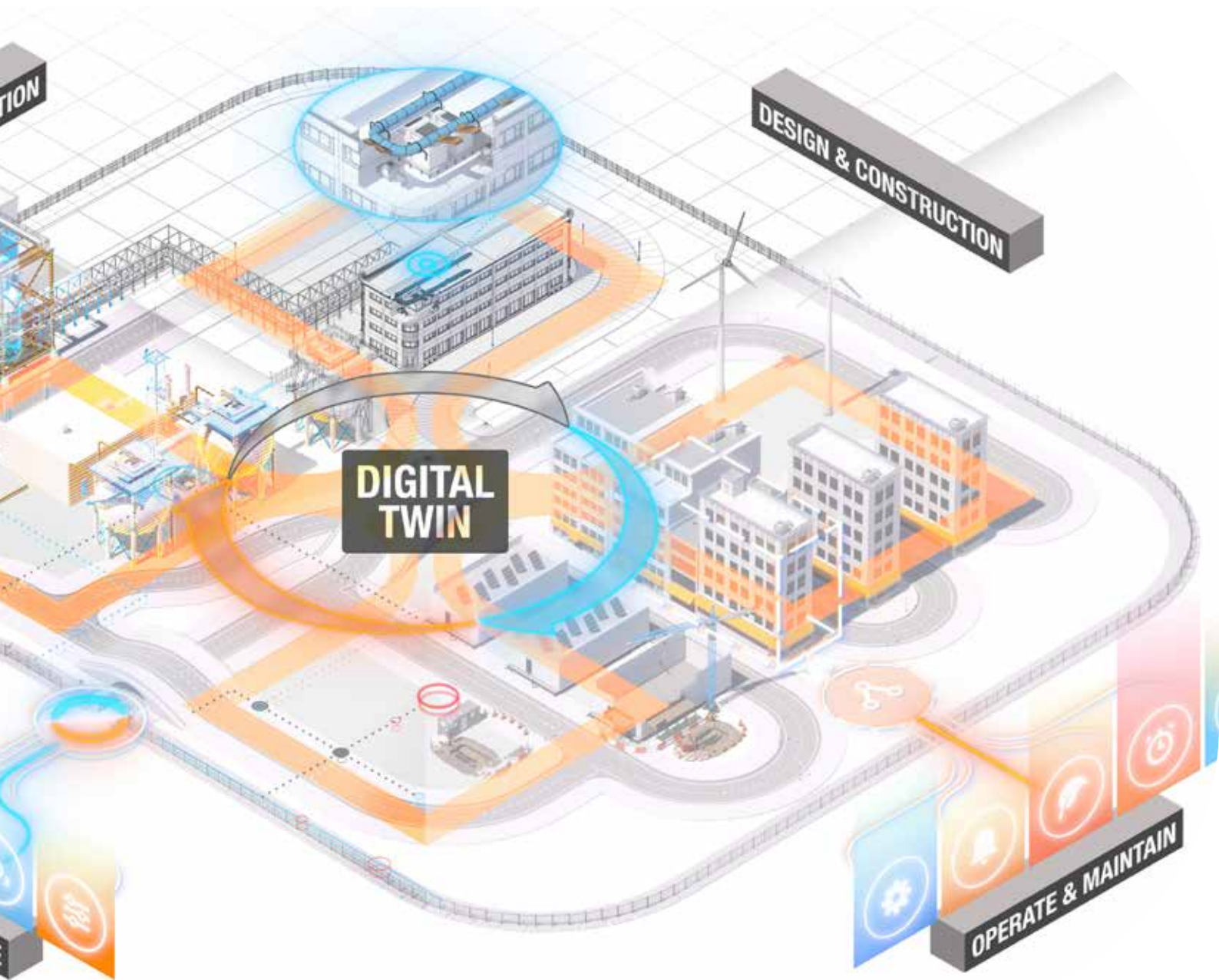

The M+M segments in detail

The following pages give an overview across the Software and Digitization segments forming the actual M+M business model.

Segment M+M Software

Economically, the M+M Software segment is a standard software developer with nearly 115 Million Euro sales (2025), around 90% gross yield and solid 28.3% EBIT margin.

As a result, the segment pulls a relatively high added value from its just 48% share in group sales. In fiscal year 2025, 56.5% of group gross profit and 66% of operating profit EBIT were achieved by the M+M Software segment.

High development investment

M+M in 2025 spent EUR 28.96 mln or 25.3% of segment sales on maintenance and development of proprietary software.

Roots in the 'Technology Offensive'

The roots of the Software segment originate in M+M's 'Technology Offensive' around the turn of the millennium, when we strengthened the proprietary added value by acquiring shares in CAD/CAM software companies.

The development since can be valued by the fact that the four companies today forming the segment had combined sales just above EUR 15 mln back in the year 2001, and had not yet reached break even.

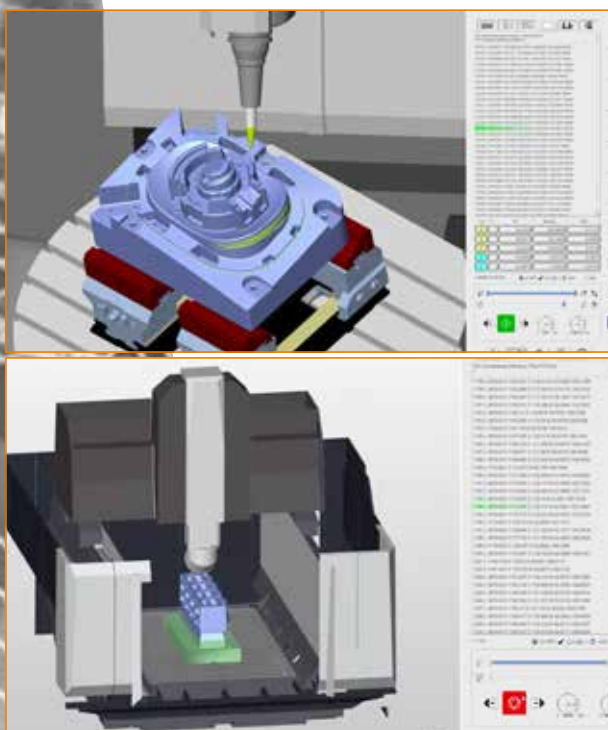

Digital twin for CAD/CAM: Virtual Machining

Project: Simulate and optimize the entire machining process

Precision machine tools are available in very different designs and axis arrangements depending on the area of application, the required size and precision. For smaller to medium-sized parts, the clamped component is usually moved via two rotation axes, while the spindle can reach any point in the machining space via three linear axes (top picture).

For large, heavy parts, so-called gantry machines are used, in which only the milling spindle is moved via three linear and two rotary axes (bottom picture). For special cases gantry machines with up to 7 axes are in practical use. There are also combined turning/milling machines and many other special shapes.

With the VIRTUAL Machining technology in *hyperMILL*, the entire machining process can be simulated and optimized virtually. Not only are the exact kinematics of the machine tool used, but also the limits of all axes, the clamping device and the entire machining process are simulated.

With the help of this 'Digital Twin' it is possible to see in advance whether a part can be manufactured on a specific machine and in what time, whether the selected positioning fits or needs to be moved, and much more. The virtual simulation also can prevent real damage to the very expensive precision machine tools.

We push machining to the limit

Software solutions from the wholly owned subsidiary OPEN MIND are used on over 20,000 seats by over 10,000 customers globally for the process control of milling, drilling and turning in various industries such as mechanical engineering, tool, mold and die making, automotive, aerospace and shipbuilding, medical technology, as well as toy, watch, clock and jewellery manufacturing.

Particularly in the highly complex 5-axis milling process, the *hyperMILL* and *hyperCAD S* product lines from OPEN MIND hold a technologically leading position and allow the customers quick payback of their high machine tool investments, which are typically in the six to seven digit range. This is the reason why Open Mind achieves EUR 30,000 per new *hyperMILL* license, a very high price for a standard software.

A variety of applications for specific products like tyre molds, turbine blades and impellers enable and simplify the programming of complex handling, lower the machining time and improve finished quality.

The product portfolio is rounded up by the innovative *millTURN* module for combined milling/turning machine tools and by the *hyperMILL MAXX* Machining package enabling enormous productivity gains by radical reduction of machining time.

hyperMILL®

Shorter milling times due to intelligent machining strategies

Benefit: Significantly faster machining of complex parts

Customers: All users of precision machine tools worldwide

Time is money – this rule is particularly applicable for precision machine tools with purchase prices in the six or even seven digit range. *hyperMILL* significantly reduces milling times through intelligent machining strategies, pushing return on investment for these expensive machine tools to completely new dimensions.

E.g. a state-of-the-art rule so far said that for ‘Roughing’, the rough material removal in the first step, classical 3-Axis machines would be more suitable, while finishing could be better done using the more agile 5-Axis precision tools.

hyperMILL breaks through this rule by the ‘helical drilling’ method plunging the cutter into even hard materials in a staggering motion, without predrilling, enabling up to 5x higher material removal for roughing, even with less tool wear and cheaper cutters.

In combination with the *hyperMILL* method to accelerate finishing of flat surfaces up to 10x by using conical cutters with slightly convex curvature, the pictured lightweight aerospace part conventionally needing more than 10 hours machining time can be milled in just over 2 hours using *hyperMILL* - a five-folding of productivity !

High efficiency gains for Modelling and Prototyping

Benefit: From idea to reality in the shortest possible time

Customers: Manufacturers of innovative products e.g. Kärcher or Stihl

The goal in modelling and prototyping is to convert ideas into physical models and prototypes as quickly as possible. As the CAM software *hyperMILL* from M+M has particular strengths here, it is used by many manufacturers of innovative products.

E.g. Kärcher, the world's leading cleaning equipment manufacturer located near Stuttgart, Germany. There are 600 to 800 prototypes per week, for which the CAD model comes in from the development department in the morning and the part should be ready in the evening. Since *hyperMILL*, including the underlying CAD software *hyperCAD S*, is programmed in-house with consistent user interfaces, it is no longer necessary to switch back and forth between several systems.

Another example: Stihl, the global market leader for chainsaws located nearby in Waiblingen, Germany. Thanks to the BEST FIT function in *hyperMILL*, parts produced in a 3D metal printer can now be quickly and precisely aligned on the 5-axis machine tool to remove support structures, which was previously time-consuming manual work.

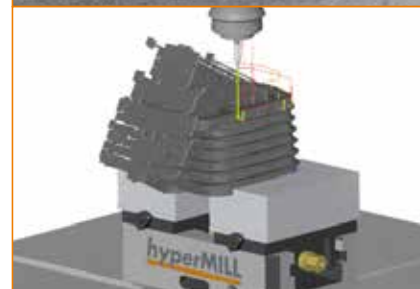
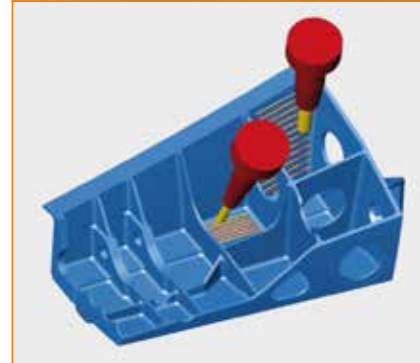
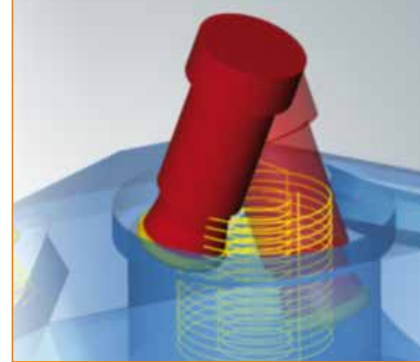



SOFISTIK is a leading technology provider of structural analysis and reinforcement software for Civil Engineering, particularly bridge, tunnel and construction design with impressive references around the world, for example the Sixth Street Viaduct in Los Angeles, USA, completed in 2022.

Over 3,000 customers in more than 60 countries on all 5 continents use SOFISTIK Software to realise their projects - from reinforcement design for a family home up

to the analysis of large scale buildings and facilities, everything of course according to various international standards.

Special modules like the Bridge+Infrastructure Modeler to design Bridges, Tunnels and other profile buildings like noise barriers, a CFD module for wind analysis (see Arnulf-park bridge on next page), or functions for seismic analysis of building safety in case of earthquakes are completing the portfolio.

SOFISTIK was founded in 1987 and in 2000 joined the M+M group, which has held a majority stake since 2019, currently 51.4%.



Sixth Street Viaduct, Los Angeles, USA / Customer: COWI North America

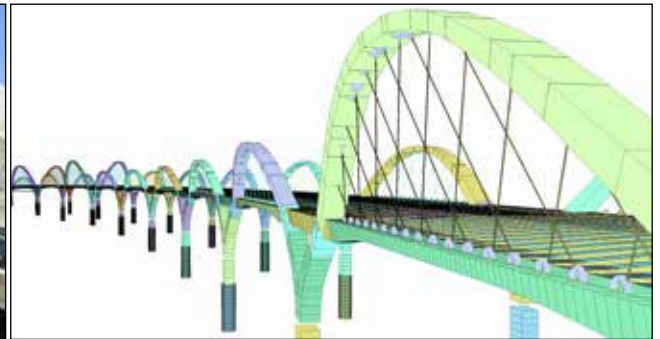

SOFISTIK BIM Computer Model

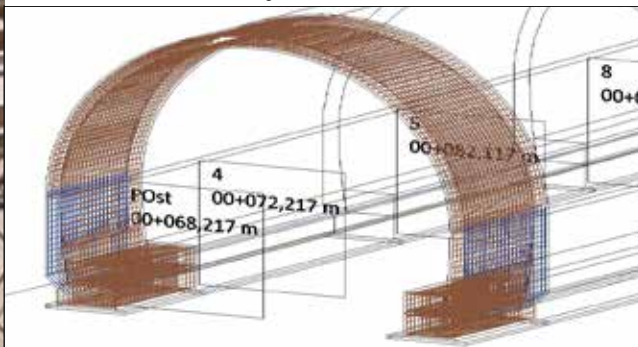

SOFISTIK Bridge + Infrastructure Modeler: Tunnel Reinforcement

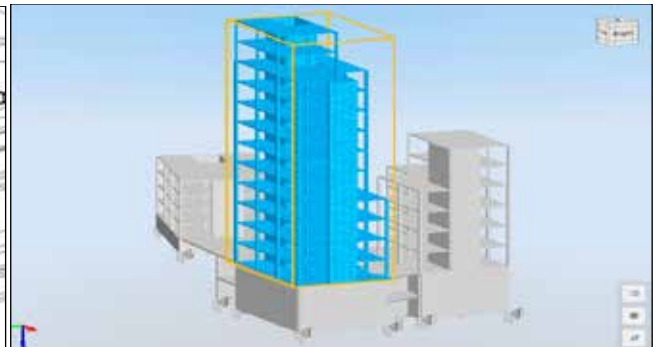

SOFISTIK Seismic Analysis

CAD in practice: Structural and dynamic analysis of bridges

Project: Arnulfpark bridge for pedestrians and cyclists in Munich

Customer: SSF Ingenieure, Munich, Germany

The foot and cycle bridge at Arnulfpark, completed at the end of 2020, over the 240 meter wide platform forecourt of Munich Central Station, spanning 37 tracks, was extremely challenging for design, construction and calculation.

In order to disrupt rail traffic as little as possible, the steel bridge structure was pre-assembled on-site and pushed in over the piers in an incremental launching process into its final position (pictures on the right).

SOFISTIK software from the M+M Group was used for the structural and dynamic calculations of the very complex bridge geometry. Particularly critical were the incremental launching phases (picture mid left) and the calculations of the vibration behavior under strong wind influences, where the CFD method (Computational Fluid Dynamics) was used to prove by computer simulation (picture mid right) that the expensive installation of vibration dampers was not necessary.

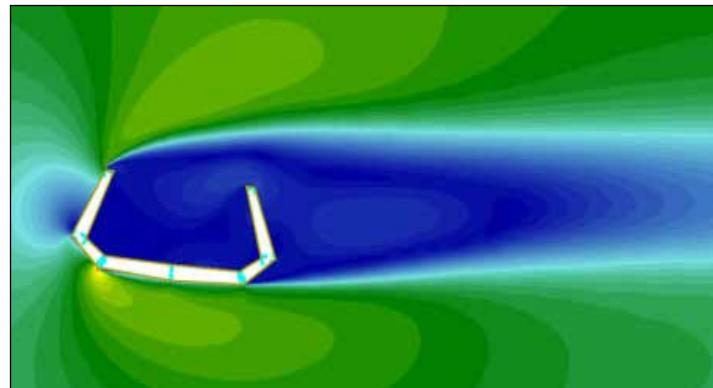
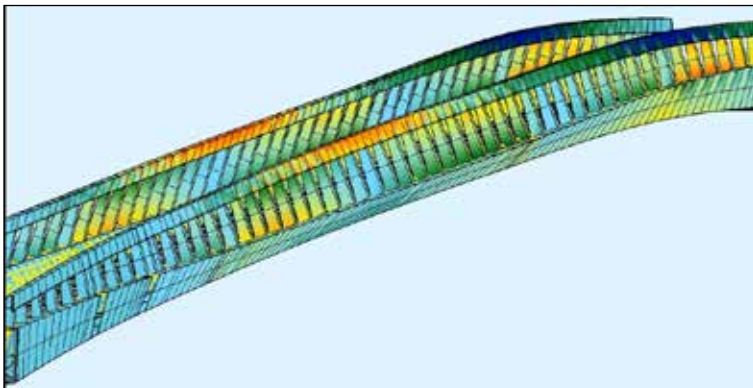

Photocredits: Hans Gössing (1/2), SSF Ingenieure (3/4/5)

DATAflor

DATAflor Software solutions for Gardening/Landscaping/Earthworks contain graphical planning including 'Digital Terrain' model and visualization, as well as commercial software, e.g. for calculation, tender, quoting, construction site controlling and billing, where artificial intelligence is being used more and more.

Take digital mail reception e.g.: whether e-invoice, PDF, or photo, the software recognizes what it is and takes care of it. Tax-relevant data are extracted and the appropriate workflow starts automatically.

Or take plant planning: Here, AI automatically analyzes location and plant information – and generates appropriate care tips.

Or the intelligent construction diary: Thanks to AI and speech recognition, construction site documentation can be easily recorded on-site using a smartphone – even in the employees' native language, which is then converted into a uniform target language using AI. Speaking instead of typing – for greater efficiency on the construction site.

DATAflor was founded in 1982 and in 1999 joined the M+M group, which has held a majority stake since 2002, currently 67.2%.

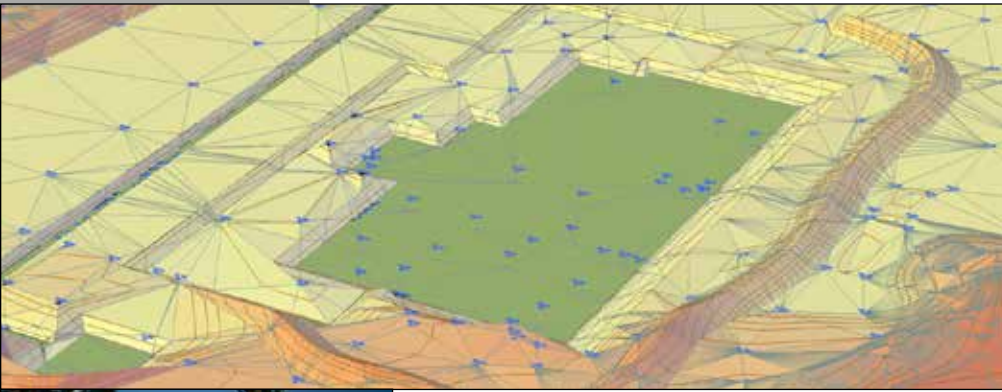

The 'Digital Terrain' module enables 3D outdoor facilities design. The software can not only read terrain data from 3D scanners or drone cameras but also output 3D terrain data to automatic excavator machine control units. Not only does this improve quality and efficiency of excavation and earth moving work significantly, but also relieves the shortage of skilled workforce, as it improves the attractiveness of the job in the excavator cab especially for younger and technology-savvy people, and it saves the previously obligatory 'second man with the yardstick' on site.



The software allows for the floor plan design of a large sports facility (Customer: AHNER/BREHM, Koenigs Wusterhausen, Germany) as well as visualization in daylight or for the effect of lighting concepts by night.



eXs

THE FUTURE OF CAE

In 2020 M+M introduced eXs, a brand new CAE software (Computer Aided Engineering) redesigned from scratch, fully data compatible and largely user interface compatible to its predecessor ecscad, proven since 1993, easing the transition for all existing users.

eXs introduces completely new CAE project concepts for the Industry disciplines of electrical and process engineering, hydraulics and pneumatics as well as for all building services disciplines in BIM projects. With its high performance database, increased functionality, simplified usability and free configurability, eXs defines new standards for CAE software.

As eXs is based, like ecscad, on the globally market-leading Autodesk standards, it is easy to fulfil the ever-increasing demand for cross-trade projects both from Industry (Mechatronics) as well as from Architecture and Construction (BIM).

eXs is developed by the 100% subsidiary M+M Mechatronik GmbH belonging to the Software segment. Sales, training and customization are largely taken care of by CAE/Manufacturing and BIM/Architecture teams in the Digitization segment and to a lesser extent by external partners.

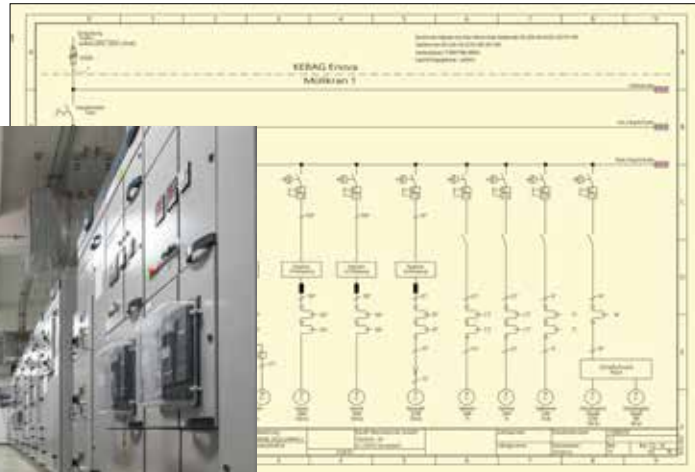

The new eXs can be used in CAE project concepts for the Industry disciplines of electrical and process engineering, hydraulics, pneumatics or mechatronics as well as for all building services disciplines within BIM projects.

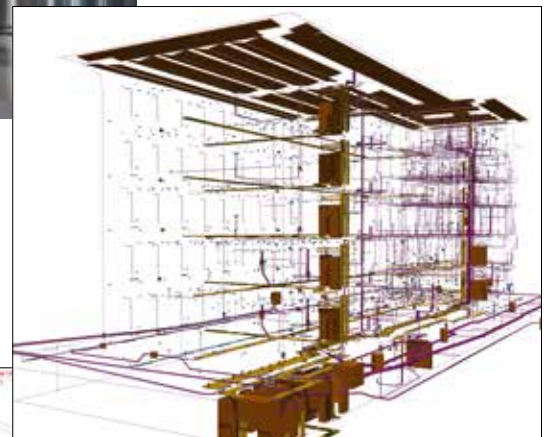



Segment M+M Digitization

With approx. 50 locations and over 500 employees in Germany, Austria and Switzerland as well as in UK, Italy, France, Poland, Romania and Hungary, M+M Digitization provides full area coverage and serves approx. 20,000 customers with interdisciplinary solutions and at the highest quality.

Dynamic growth

The segment emerged in 2009 from the Autodesk Distribution (wholesale), which had previously been in operation for 25 years.

The transition was supported by acquisitions of sales partners and the divestment of the distribution rights, so that the 2009 gross profit of EUR 13.4 mln was nearly sixfold in the following 16 years to EUR 79.1 mln in 2025, and 13.5% segment EBIT margin could be achieved.

High proprietary business contribution

Gross profit in the M+M Digitization segment is composed from proprietary M+M business (e.g. customizing, own software, training, support) and the commission or resale margin of third-party software from Autodesk and other providers.

Growth drivers: Training ...

The growth in proprietary business is firstly based on strong demand for training in the sectors Construction and Manufacturing, where M+M has set standards with its BIM Ready and CIM Ready (CIM: Computer Integrated Manufacturing) training programs.



Digitization in practice: Fully automated variant design

Project examples: Electric distribution boxes and Gastronomy showcases

Customers: Bals Elektrotechnik, Germany and Beer Grill AG, Switzerland

M+M's configuration software customX enables up to 90% productivity improvement by automated variant product design of any complexity. After Web entry of customer requirements, all necessary calculation and production documents are generated automatically and correctly.

Example 1: Bals Elektrotechnik configure individual customer specific electric distribution boxes, including an interface to their ERP system SAP HANA.

The internal workflow from offer through order entry to production has been accelerated to the extent that even single-item production is absolutely economical.

Example 2: At Beer Grill AG, where all possible combinations can be selected for each product line, from the size of the showcase to temperature control and lighting as well as the color of the decor. customX immediately checks whether the entries are plausible and generates dimensional drawings, visualizations, design drawings, bill of materials - in short, everything that is initially required for the offer and later for production.



... and digitization projects

The second growth driver are customer specific digitization projects, in which standard software modules are connected to individually tailor-made project solutions, adding functionality where necessary.

In order to avoid re-inventing the wheel in each project, M+M has developed a growing library of application software and content to adapt the Autodesk product portfolio, which is developed for global use, to the specific requirements in Germany, Austria, Switzerland and other European countries, e.g.:

- Data management for Industry 4.0

pdm  booster

- Solution for Architecture/Construction

bim  booster

- Digital factory/city / BIM for Infrastructure

map  edit

- Variant design / configurator software

custom  X

M+M's customer specific projects can range from few man-days to several man-years. Large projects are usually cut into several segments. Project development altogether contributes a significant share to service gross profit in the Digitization segment.

To provide optimal professional consulting quality to customers from different sectors, the M+M Digitization segment organisation has competence teams for Manufacturing, Architecture/Engineering/Construction/Operation (AECO) and Infrastructure. On our local Websites there are a lot of interesting reference stories about customers and projects from these teams. Four examples are displayed here and on the next page, in short.



Digitization in practice: Building Information Modeling/Management (BIM)

Project: BIM introduction and training for a large railway operator

Customer: Deutsche Bahn AG, Berlin, Germany

All disciplines of a building, including time and cost dimensions, working together in 3D, collaborating, and sharing information via a common database, that's BIM. Due to the holistic approach of this new method, high time and cost savings can be achieved in all phases (Planning, Construction, Operation).

Deutsche Bahn AG is one of the BIM pioneers in Germany, continuously working with its subsidiaries to improve their standards. After a pilot phase lasting several years, the BIM method is now used in all new projects.

M+M has been a DB partner with the BIM Ready training program for years and organizes information forums for planning and project employees such as the DB BIM Messe in Berlin. Some DB departments and many external DB partners are using M+M's BIM Booster in planning, quantity takeoff and model checking, as well as the engineering software from M+M Group member SOFiSTiK in the areas of bridge design and calculation.

bim  ready

bim  booster

 SOFiSTiK

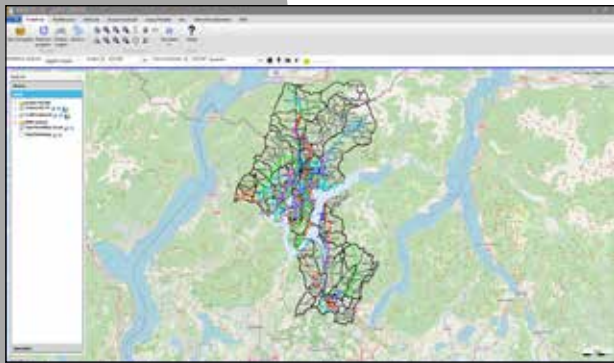

Kunde: Stadtwerke Lugano (AIL), Schweiz/Switzerland

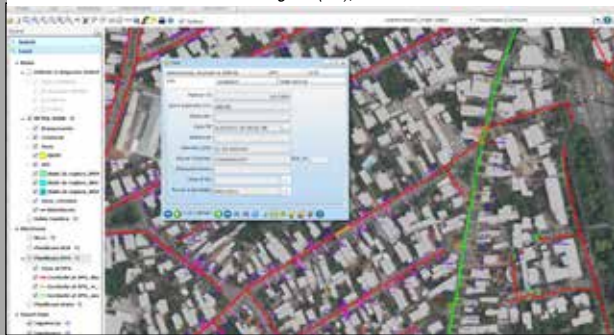

Kunde: Engie Romania SA, Rumänien

mapedit

Digitization in practice: BIM for Infrastructure

Projects: M+M MapEdit as a data hub for the Digital City or Factory

Customers: Municipalities, Suppliers, Industry, Ports/Airports, Planning Offices...

M+M's Infrastructure software MapEdit is used on approx. 2,500 seats by nearly 200 customers in Germany, Switzerland and other European countries to connect geo and land register data with other data sources to digital city or factory twins, enabling any type of inquiry by internal or external users easily via the web.

Specialist applications like area or development plans, tree or property cadastre, land value calculation, electricity, gas, water, waste water, telecommunications, district heating, plant topography, emergency management, incident documentation etc. are available. Thousands of users can access the MapEdit data hub at the same time, no matter whether from specialist departments, for citizen information via the web or by mobile maintenance technicians on site.

Further Information: www.mapedit.de/en

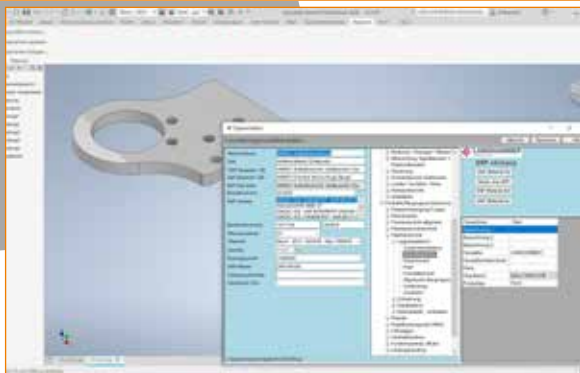
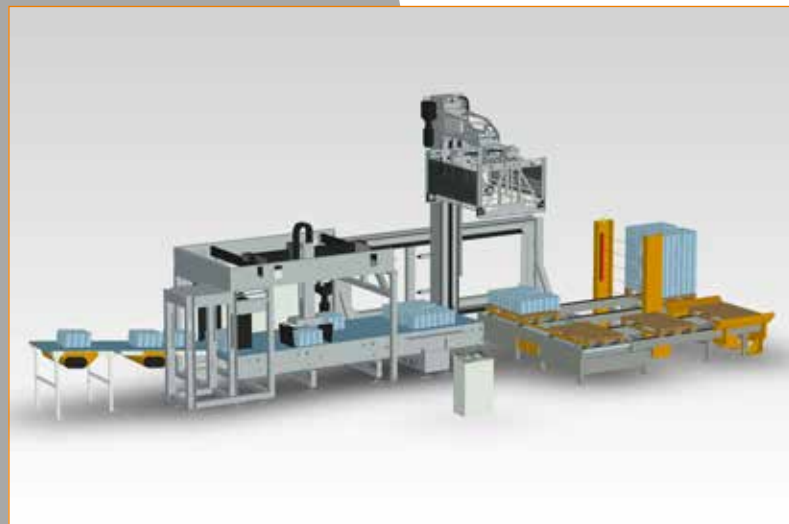

pdm booster

Digitization in practice: Product Data Management (PDM)

Project: Connecting design data and commercial information

Customer: Koerber Supply Chain GmbH, Eisenberg, Germany

Connecting design data and commercial information is a standard request from our industry customers, however with very individual challenges and complexities depending on the situation. Therefore M+M developed the product line PDM booster, which is currently in use in thousands of customer seats.

For example at Koerber Supply Chain GmbH, a manufacturer of special machines for intralogistics and palletizing technology, who sought help from M+M to streamline their own design processes.

Today, the PDM booster links the CAD systems with SAP. Media breaks between design, work preparation and purchasing have been eliminated, and many automatic functions make work easier. Conclusion: The employees are very satisfied, the data quality has been significantly improved and the time for material master creation and maintenance in SAP has shrunk by half.

Allocation of gross profit

In the year 2025 Mensch und Maschine achieved 56.5% of value added metric gross profit in the Software and 43.5% in the Digitization segment, distributed over many different sectors across the manufacturing, construction and infrastructure industries.

Manufacturing generates approx. 55%

Manufacturing continued to account for the largest share of the EUR 181.9 mln gross profit achieved in 2025 at around 55%, divided into the following two blocks:

Largest block: M+M's CAD/CAM software

M+M's own hyperMILL CAM software (top sector in the diagram), together with the CAD core hyperCAD S, also developed in-house, forms the largest value-added block. The target group here are all owners and buyers of precision machine tools globally.

Longest tradition: Digitization Manufacturing

The tradition of our Manufacturing (MFG) team in the Digitization (formerly VAR) segment goes back to the founding of M+M. The focus: training (CIM Ready) and digitizing projects based on eXs, customX, PDM booster for customers in Mechanical/Electrical and Process Engineering, Automotive/Aerospace/ Shipbuilding, Mold/Tool Making, Hydraulics, Pneumatics (left sector in the diagram).

Architecture/Construction approx. 35%

Architecture/Construction, with around 35% gross profit share the second-largest area, is also divided into one block each from the Software and Digitization segment:

M+M Software: DATAflor and SOFiSTiK

DATAflor is aimed at architects and contractors in gardening, landscaping and earthworks, primarily in the D/A/CH area, while SOFiSTiK globally supports planners and construction companies in civil engineering, bridge, tunnel and building design (right sector).

The BIM professionals: Digitization AEC

The Architecture/Construction/Engineering (AEC) team with its BIM professionals takes care of digitization (BIM booster) and training (BIM Ready) for structural and civil engineering, building services and facility management customers (bottom right).

Around 10% hybrid: MFG & AEC

An estimated 10% of gross profit is not directly attributable to MFG or AEC, but is hybrid in between. Infrastructure with Map-Edit contributes here, but also CAE with eXs and variant design with customX as well as the area of construction suppliers from manufacturing is allocated here (bottom left).

Common Base: Autodesk standards

Except for CAM, most M+M solutions are based on CAD standards from Autodesk, primarily AutoCAD, Revit, Inventor and Vault. This light blue field in the diagram stands for the part of group's gross profit generated (across all sectors) by Autodesk margin or commission in the Digitization segment. In the Software segment, license payments to Autodesk are cost of materials.

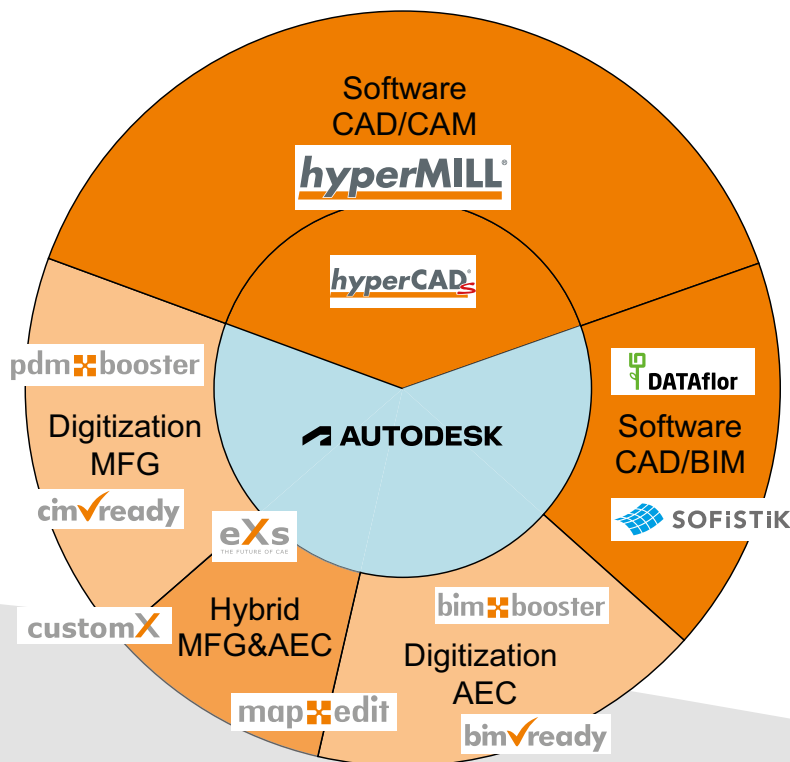

Ecology and Economy in harmony

Probably the most effective contributions to the reduction of global CO₂ emissions are, on the one hand, energy savings and, on the other hand, replacing fossil-based power generation with regenerative ones.

Both methods also have the advantage that they not only make ecological sense, but also deliver direct economic return.

That is why Mensch und Maschine has been active on both paths for a very long time.

M+M as a regenerative power producer ...

We are using all suitable roof surfaces in corporate ownership for regenerative power production, totalling approx. 200 MWh p.a.

As early as 2011 M+M's first photovoltaic plant had been installed on the roof of our Training Center in Wiesbaden.



The new SOFISTiK building in Nuremberg with solar+geothermal and the new DATAflor Technology Center in Goettingen with solar plus cogeneration unit followed in 2019/20.

In September 2021, an approx. 1,500 square meter photovoltaic system was installed on the roof of M+M headquarters in Wessling.

As replacing coal-fired by solar electricity saves around one kilogram CO₂ emissions per kWh (Source: strom-report.de), M+M thus is achieving approx. 200 metric tons of CO₂ savings per year. Moreover, ecology and economy are in full harmony: The new power plant on the headquarters roof will have amortized after approx. 10 years.

... compensates 6.5% of CO₂ footprint

As a pure think tank with just over 1,100 employees (full-time equivalent), M+M does not have a very large CO₂ footprint: Assuming around 7 tons of CO₂ per head & year and a professional/private distribution of 40/60%, the annual total is approx. 3,100 tons of CO₂ for the M+M group.

Thus we compensate approx. 6.5% of our CO₂ footprint by regenerative power generation.

The 1,500 square meters photovoltaic system on the roof of M+M headquarters in Wessling takes up the entire useful roof area and has been supplying green electricity since October 2021.



The M+M business model is based on resource savings for customers ...

A much greater effect is generated at the level of M+M customers - through our business model, which is consistently based on process optimization and the associated savings in resources:

A precision machine tool that finishes two to five times faster also consumes correspondingly less electricity (see pages 6/7).

The same applies when customers accelerate their technical processes with eXs, customX or PDM Booster (pages 11/12/14).

Or when BIM Ready training and the use of BIM Booster enable more effective planning and resource-saving construction (page 13), or when large infrastructure operators can achieve their ambitious sustainability goals more quickly through MapEdit (page 14).

A structure planned and calculated with SOFiSTiK software uses less steel and concrete or can alternatively be made of a more environmentally friendly material such as wood (pages 8/9).

And with the Gardening/Landscaping design software from DATAflor, gardens or parks are created that make a direct contribution to CO₂ reduction (page 10).

It can therefore be assumed that the main motivation of M+M customers is to save resources with the help of our technical software and digitization solutions - hence a direct correlation between the turnover of the M+M group and CO₂ footprint reduction of our global customers is likely to exist.

The level of this correlation certainly cannot be quantified exactly, but it can be estimated approximately based on customers' electrical energy savings:

Assuming an electricity price of 25 cents per kWh and CO₂ emissions of 250 grams per kWh (estimated average values for our customer/country mix), one million Euros less in electricity expenses corresponds to 1,000 tons savings of CO₂ emissions.

... which should be enough to more than compensate the M+M CO₂ footprint

In relation to M+M's approx. 3,100 tons CO₂ footprint, this means:

If our customers save only EUR 3.1 million in electricity costs by using our software (that would be approx. 1.3% of the M+M turnover), we are already CO₂-neutral.

Realistically, a significantly higher savings rate can certainly be assumed for our customers, moreover since the above calculation only refers to electrical energy and all other resource savings would have to be added.

The significant reduction of machining times by M+M's CAM software goes hand in hand with accordingly less power consumption (and tool wear). Good for the machine operator - and the environment.



Digitalization is Sustainability: The environmental protection practiced by M+M through digitalization does not cost customers any additional money, but on the contrary reduces costs and thus fully balances ecology and economy.



Workforce (FTE)

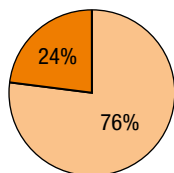

Management

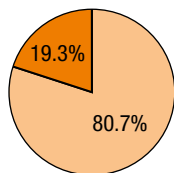

Admin Board

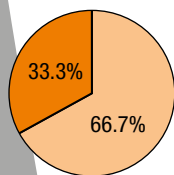

■ Female
■ Male

Group headcount just rose moderately

Group gross headcount at Dec 31, 2025 was 1,192 persons (PY: 1,179 / +1.1%). The average full time equivalent (FTE) 2025 climbed to 1,127 (PY: 1,095 / +2.9%), with 593 / 53% (PY: 570 / 52%) in Software and 534 / 47% (PY: 525 / 48%) in Digitization.

Industry-typical gender quota

The proportion of women was 26% (gross) or 24% (FTE). This reflects the unfortunately very weak supply of female specialists in technical professions and the significantly higher share of part-time female employees. Nevertheless, M+M has a female proportion of 19.3% in the management teams.

Employees are co-entrepreneurs

Traditionally, there is a very high focus on good corporate culture at M+M. During the 42 years since foundation, our employees were always seen as 'Co-Entrepreneurs' and fully integrated in the decision making process.

Whenever acquiring companies in and outside Germany in the course of the intensive expansion since IPO in 1997, M+M always cared for and respected the specific culture of the companies acquired.

The decision making structures in the M+M group are as decentralised as possible. The individual entities have a high degree of autonomy in order to be able to optimally meet the customers' requirements and to achieve the best possible results in the individual markets.

Experienced management team

This corporate culture generates a high degree of continuity. Staff turnover in the M+M group is very low, which even during the hype phases of the IT industry prevented a drain of qualified specialists from which other similar companies in IT suffered. As a result, M+M has an experienced management team down to the second and third management level, with team members mostly looking back on an employment period of more than 15 years.

Apprenticeship and qualification:

Approach vs. shortage of skilled workforce
M+M offers apprenticeship and is very active in employee qualification. In addition, there are cooperations with local universities and colleges at many locations. In this way, we increase our attractiveness as an employer and actively counteract the lack of skilled workforce that is also latent in our industry.



Boubacar Likeng started working for M+M in Paris in 1998. Since 2012 she has been head of M+M France.

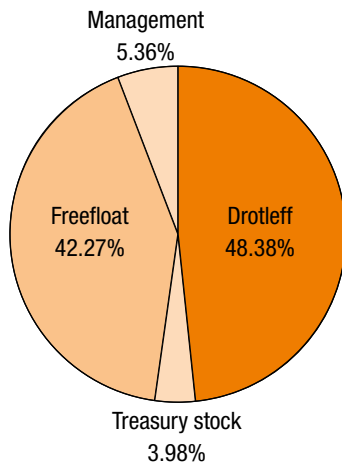

Entrepreneurial and public company

Though M+M shares have been listed on the stock market for 29 years, a large portion of the shares are still in the hands of the management. Founder Adi Drotleff held 48.38% on Dec 31, 2025, other management members held further 5.36% of shares.

Trading under 'European SE'

In 2006, the parent company was converted from AG to SE. In parallel, a structure with M+M SE acting as pure finance holding was realized. Central group functions are executed by the subsidiary M+M Management AG, while all operating business is performed by German and international subsidiaries.

Due to the founder's controlling interest, a 'monistic' instead of the dualistic AG board structure was chosen for M+M SE, which, from a corporate governance point of view, is much better suited for an owner-managed and at the same time public company.

Monistic SE board structure

In the Administrative Board, combining the AG's Advisory Board ('Aufsichtsrat') functions with those of an administrative body ('Organ'), Drotleff holds the controlling majority together with his wife Heike Lies, while Dr. Rupprecht von Bechtolsheim as independent member represents the interests of free shareholders.

The Board of Managing Directors ('Geschäftsführende Direktoren'), equalling the 'Vorstand' of a German AG without being a legal body ('Organ'), consists of Adi Drotleff and CFO Markus Pech (Group finance and admin).

The founder as an 'active Chairman'

Since Jan 1, 2023, Drotleff is at his own request only simple member of the board of directors with reduced remuneration, since he had largely withdrawn from daily business from 2019. As an 'active Chairman' he concentrates on Group Strategy and Communications.

Control by Group Management Board

More than 10 years ago, Drotleff had set up the Group Management Board staffed by the Managing Directors and the heads of the large operating units.

In addition, other members of the upper management levels take part in the regular board meetings as required.

Listed in scale and m:access

The M+M share is listed in the premium SMB segments scale of Frankfurt stock exchange and m:access of Munich stock exchange.

Both segments prescribe, for admission, consequential duties above and beyond legal requirements, guaranteeing a high degree of transparency. In M+M's view, they are ideal market segments for achieving a reasonable cost-benefit ratio of a stock exchange listing in relation to the market capitalisation, protecting the legitimate interests in transparency of the shareholders.

Due to the requirements for disclosure and transparency these market segments represent fully operational markets with protective mechanisms that are very close to that of the regulated market and that guarantee the marketability of the shares including the tradability through Xetra.

In addition, M+M is highly overfulfilling the scale and m:access rules by publishing full quarterly reports and German/English IFRS reporting.

Risks and Opportunities

The operations and activities of the M+M group are subject to various risks.

In our risk management system, sources of uncertainty are systematically identified, documented, evaluated and as far as possible controlled.

In all business units there are so called risk owners, responsible for the description, evaluation and control of risks in their fields. All units' risks are documented in a risk inventory together with the initiated counteractions, and the remaining risk is evaluated. The evaluation takes into account the likelihood of occurrence and the impact on the group.

The risk inventory with its documentation of counteractions, together with the monitoring of various early indicators, allows control of the development of a risk. The reduced risk impacts and likelihoods of occurrence after successful counteractions, are duly monitored and reported to the Managing Directors.

The remaining risks, particularly, are taken into account in business planning.

The accounting is integrated into the risk management, which allows identification and evaluation of risks which are in conflict with the compliance of the group financial statements. At this stage, we cannot see any such risks.

The whole accounting is subject to efficient control mechanisms. These particularly include extensive monthly reporting and liquidity planning, which are controlled in detail. Additionally, there is a regular review concerning specific items.

In addition, the financial transactions are supervised continuously. Within finance and accounting, there is additional protection by the principle of dual control. Systematic limit controls (e.g. for open sales orders or for capital expenditure invoices) supplement the control mechanisms.



In detail, the following risk categories exist:

Credit risks:

Bad debt risks are counteracted with customer credit insurance, individual bad debt provisions, and streamlined receivables management.

Also favourable in this respect, is the fact that sales are divided among many individual customers each of which carries less than 1% of the total group revenue.

Warehouse and transport risks:

The risk of loss in value during warehousing can be considered low due to very low stock level and fast turnover.

Transport risks are generally covered by corresponding insurance contracts.

Sales and market risks:

As with every other supplier of standard software, M+M is subject to software market and product cycles, especially those of the CAD/CAM/BIM market. Such risks are generally counteracted, as far as possible, by the vertical and regional division of the M+M Group and by the spread across several product lines, but risk may not always be fully compensated by these actions.

Personnel risks:

As an enterprise in the soft ware industry, M+M is, in principle, dependent on individuals with special skills.

M+M's distinctive corporate culture, so far, has been instrumental in keeping employee turnover exceptionally low.

The risk of dependence upon key top management people has been counteracted by appointing several Managing Directors and by strengthening the secondary management level.

Supplier risks:

Concentration on the main supplier Autodesk represents a certain risk through dependency on this supplier's product development, market competence and operational policy.

Losses at subsidiaries and shareholdings:

In all shareholding or subsidiary relationships, it is recognised that there is a risk that, contrary to positive expectations, a negative development may occur possibly proceeding to total loss.

This would cause an appropriate impairment of goodwill or investment value.

Financing and liquidity risk:

As in any business model not exclusively financed by equity, there is a dependency risk for the debt financed part due to the refinancing capabilities of the financial market. This risk is counteracted by distribution of credit lines at several banks inside and outside Germany. It cannot be excluded, however, that the refinancing interest rate payable by M+M may develop negatively or the refinancing by debt may fail in parts or in total. Due to the positive balance sheet development in recent years, M+M now has a net liquidity surplus, so this risk has become less important.

Cyber risks:

Like any other company, M+M is exposed to various cyber risks, which are countered with a bundle of measures. This includes, in particular, securing critical data sets, ongoing training and raising awareness of all employees about the topic of cybercrime and much more.

M+M is certified according to ISO 27001 and TISAX regarding information security.

Opportunities result from the successful execution of our general strategic concept. These are detailed in the 'Outlook' section.

Course of business 2025 and situation of the group

Revenue & gross profit (in MEUR)

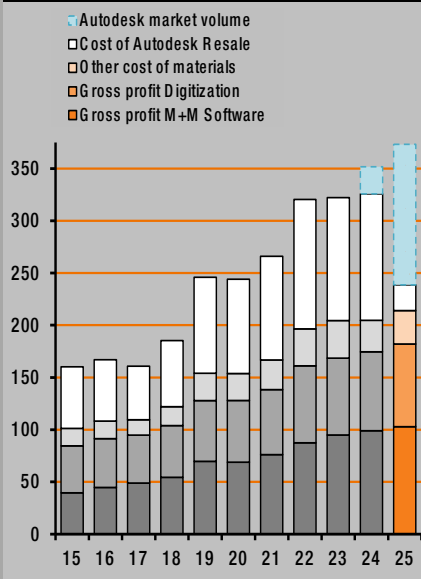

Earnings & Dividends (in MEUR)

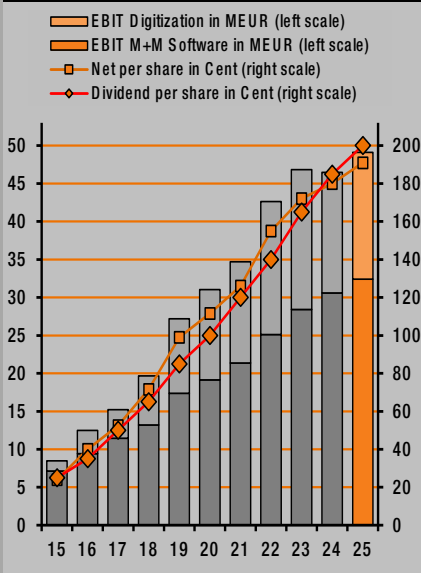

M+M back to profit record track

Mensch und Maschine Software SE (M+M) in 2025 continued to lay a very solid foundation for the future with high investments in internal IT systems, the Autodesk transition and the development of our own software products. Despite the associated burdens we returned to our long-term profit record track.

Autodesk transition affecting sales

Group sales amounted to EUR 238.59 mln (PY: 325.84 / -27%), with EUR 114.47 mln (PY: 109.32 / +4.7%) from M+M Software and EUR 124.11 mln (PY: 216.52 / -43%) from Digitization, where after the switch from resale to commission, the majority of revenues from non-value-adding Autodesk purchase has been eliminated. The market volume managed by M+M, including revenues invoiced directly by Autodesk, however climbed by approx. +6% to over EUR 373 mln.

Record gross profit +4.2% above PY

Gross profit climbed to record EUR 181.88 mln (PY: 174.59 / +4.2%), with EUR 102.74 mln (PY: 99.02 / +3.7%) from M+M Software and EUR 79.14 mln (PY: 75.57 / +4.7%) from M+M Digitization.

The Autodesk transition pushed gross margin to 63.8% (PY: 34.9%) in the Digitization segment and to 76.2% (PY: 53.6%) in the Group.

In the 10 years since 2015, gross profit on average climbed by +8.0% per year, with a much more steady development than sales.

Costs include non-operating expenses

The personnel costs increase to EUR 110.36 mln (PY: 104.81 / +5.3%) was largely caused by non-operational expenses resulting from the personnel consolidation carried out. Other operating expenses decreased to EUR 21.28 mln (PY: 22.21 / +4.2%), while other operating income increased to EUR 10.19 mln (PY: 9.17 / +11%).

Record EBITDA EUR 60.42 mln / +6.5%

Operating profit EBITDA before depreciation, amortization, interest and taxes increased to EUR 60.42 mln (PY: 56.74 / +6.5%).

Depreciation amounted to EUR 4.21 mln (PY: 3.96) for fixed assets, EUR 6.58 mln (PY: 5.78) for depreciation leasing (IFRS16) and EUR 0.52 mln (PY: 0.52) for amortization on purchase price allocation (PPA).

Record EBIT - margin jump to 20.6%

Operating profit EBIT before interest and taxes reached a new record level of EUR 49.11 mln (PY: 46.47 / +5.7%).

M+M Software contributed EUR 32.40 mln (PY: 30.59 / +5.9%), the Digitization segment EUR 16.71 mln (PY: 15.89 / +5.2%). EBIT margin jumped to 20.6% (PY: 14.3%).

Ten-year EBIT growth +19% p.a.

In the 10 years since 2015, EBIT at +19% p.a. expanded significantly disproportionately to gross profit at +8.0% per year.

Return to normal quarterly pattern

After the rollercoaster ride caused by the Autodesk transition last year, the quarterly seasonality returned to our normal pattern, with strong Q1/Q4 and a softer mid-year.

Revenue seasonality was driven by the resale boost in Q3/24 and the Autodesk transition from Q4/24 to Q3/25. Gross profit and EBIT consolidated in the first three quarters of 2025 close to the prior year's figures, then recovering from the previous year's dip in Q4 with a +17% increase in gross profit and a +42% increase in EBIT.

Quarterly revenue:

Q1: EUR 66.02 mln (PY: 100.87 / 2023: 103.06)
 Q2: EUR 54.85 mln (PY: 75.10 / 2023: 71.32)
 Q3: EUR 56.24 mln (PY: 94.10 / 2023: 67.84)
 Q4: EUR 61.48 mln (PY: 55.77 / 2023: 80.09)

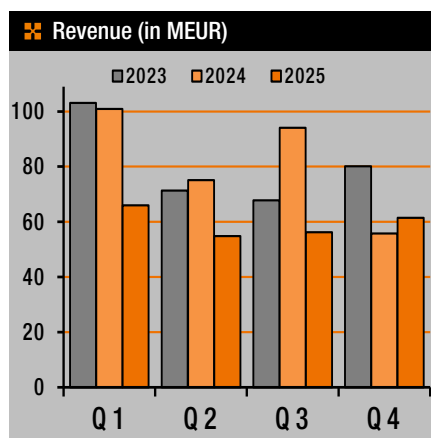

Quarterly gross profit:

Q1: EUR 49.44 mln (PY: 50.18 / 2023: 47.09)
 Q2: EUR 43.88 mln (PY: 43.36 / 2023: 40.97)
 Q3: EUR 42.38 mln (PY: 41.52 / 2023: 37.95)
 Q4: EUR 46.18 mln (PY: 39.54 / 2023: 42.53)

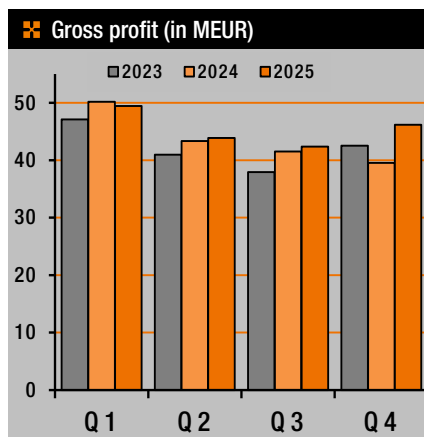

Quarterly EBIT:

Q1: EUR 16.11 mln (PY: 16.86 / 2023: 15.81)
 Q2: EUR 10.65 mln (PY: 11.12 / 2023: 10.52)
 Q3: EUR 10.42 mln (PY: 10.11 / 2023: 8.08)
 Q4: EUR 11.92 mln (PY: 8.38 / 2023: 12.42)

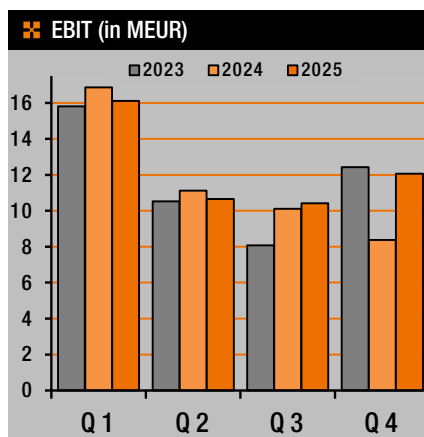

Pretax profit increased to EUR 47.06 mln (PY: 45.53 / +3.4%). Income tax rate fell to 25.84% (PY: 26.57%), tax charge amounted to EUR -12.16 mln (PY: -12.10 / +0.5%).

10-year increase in net profit: +23% p.a.

After tax and minority shares amounting to EUR 3.09 mln (PY: 2.95), net profit reached a new record at EUR 31.81 mln (PY: 30.49 / +4.3%) or 191 Cts/share (PY: 180 / +5.9%). In the 10 years since 2015, net profit climbed by +23% p.a.

Operating cash flow lower, as expected

Operating cash flow, which had benefited significantly from billing time differences for Autodesk 3YR contracts in 2023/24 and is coming in correspondingly lower in 2025/26 due to the technical counter-effect, amounted to EUR 16.58 mln (PY: 62.32) or 99.5 Cents per share (PY: 348).

Dividend proposal 200 Cents (+8%)

Management will propose to the annual shareholders' meeting on May 12, 2026 to pay 200 Cents (PY: 185) dividend per share. 100 of 200 Cts can be paid out pre-tax from the 'steuerliches Einlagenkonto' (§27 KStG). The maximum total payout is EUR 34.30 mln, the exact amount depends on the then actual number of shares in treasury stock. As in previous years, we plan to optionally offer cash or share dividend.

Dividend increased tenfold since 2014

In the 11 years since 2014, the dividend has thus increased tenfold from 20 to 200 cents - +23% growth p.a. over both 11 and 10 years.

Investing activities

As in the M+M business model the main future investment is in the area of software development, the expenses for which are mostly not capitalized, there is only relatively small capital expenditure necessary.

In 2025 capital expenditure amounting to EUR 11.05 mln (PY: 10.93) was mainly spent on the renewal of fixed assets (e.g. internal IT projects and new software developments in the areas of CAM, Cloud and eXs) and on subsidiary shareholdings.

Balance sheet leaner by commission model

The balance sheet total is streamlined by the new Autodesk commission model, decreasing to EUR 201.16 million as of Dec 31, 2025 (PY: 211.89 / -5%). Shareholders' equity as of Dec 31, 2025 decreased primarily due to share buybacks, which represent a shift of equity into hidden reserves (see page 57), to EUR 84.76 mln (PY: 104.91 / -19%), and the equity ratio to 42.1% (PY: 49.5%).

New Autodesk partner model:**Less non value-adding revenue ...**

The change in the partner model from resale to commission executed by Autodesk from Q4/2024 reduces revenue by non value-adding parts of cost of materials and in return is improving our profit margins.

... but significantly more profit margins

The revenue and gross profit chart on page 22 shows how Autodesk's resale share of material costs declined drastically in 2025. The remaining portion is due to the fact that the 'Government' business continued to operate in resale mode.

Since M+M remains fully responsible for the support of its Autodesk customers and the new model simply involves invoicing directly by Autodesk, we now also show our total 2025 market volume of over EUR 373 mln (PY: 350 / +6%) in the revenue chart.

The M+M headquarters in Wessling near Munich, also used as a solar power plant (-> page 14)



Review and Outlook

During the past ten years since 2015, gross profit has gained +8.0% per year, while EBIT grew clearly disproportionately by +19% per year. This sustainable profit increase was achieved by just +5.0% p.a. growth in operating expenses (Opex).

Active & decentral cost control ...

This is reached by actively controlling costs at approx. 2/3 of gross profit development, decentralized at the level of around 100 profit centers, into which the M+M business is divided regionally and by sectors. This development is shown in the graphic on the right, with Opex and EBIT stacked on each other forming the gross profit. It is easy to see that the model worked well even during short-term dips in gross profit.

... working well even in difficult phases

E.g. in 2017, when Autodesk's transition from software license sale to subscription damped gross profit growth to just +3.7%, but flat expenses led to disproportionate +22% EBIT increase.

Or during the Corona situation, when consistent cost management in the two-year period 2020/21 was able to generate an EBIT jump of +28% from just +8.2% in gross profit.

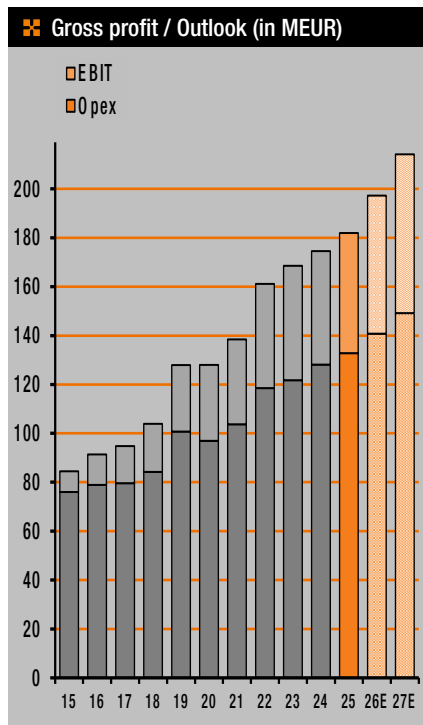

Highly scalable business model ...

This shows that M+M has a highly scalable business model and is able to generate disproportionate profit increases through its active and decentral cost control, even and above all in challenging phases.

... with a high dividend payout ratio ...

By accounting for the lion's share of software development as operating cost (10 years 2016-25: share 93.7%), M+M can afford a high dividend payout ratio without endangering our future.

... remains our strategy for the future

Also for the future, it is M+M management's clear goal to grow sustainably and profitably by consequent continuation of this strategy.

Target: Doubling earnings in 5 years

Our mid-term target is to double earnings in 5 years, i.e. net profit/share (EPS) of more than 380 Cents by the year 2030. This perspective is based on an average gross profit growth of +8% p.a. with an annual fluctuation range of 6% to 10%.

With the average profit growth of +15% p.a. required for a doubling in five years, we expect an annual fluctuation range of between 11% and 19%.

2026E: EPS/EBIT +11-19% / Div. 220-240 Cents

For the current financial year 2026, the target corridor is therefore +11-19% to 211-226 Cents for EPS, EUR 54.5-58.5 mln for EBIT, and 220-240 Cents for the dividend.

2027-30E: +11-19% for EPS/EBIT/Dividend

The target range for subsequent years remains at +11-19% for EPS, EBIT and dividend.

All estimates subject to error

All forward looking statements and targets mentioned herein are subject to market conditions occurring in line with estimations in the planning models set up by the management. Therefore no guarantee can be undertaken for meeting the estimates.

Target achievement 2025

The net profit target '196-214 Cents/share' for 2025 from the annual report 2024 was narrowly missed, as was the dividend target of '205-215 Cents'.

Events after the balance sheet date

There were no material events after the balance sheet date.

Expression of thanks

We would like to take the opportunity to thank all employees for their engaged work, which helped M+M to achieve new record results in the year 2025, which remained quite challenging due to the retarding effects of the system changes and the economic environment.

In addition, we would like to express our thanks to our customers, suppliers and shareholders for their continued loyalty to M+M. We will do our very best to keep deserving this loyalty in the future.

Wessling, March 2026
Mensch und Maschine Software SE
The Managing Directors

Entwicklung der MuM Aktie

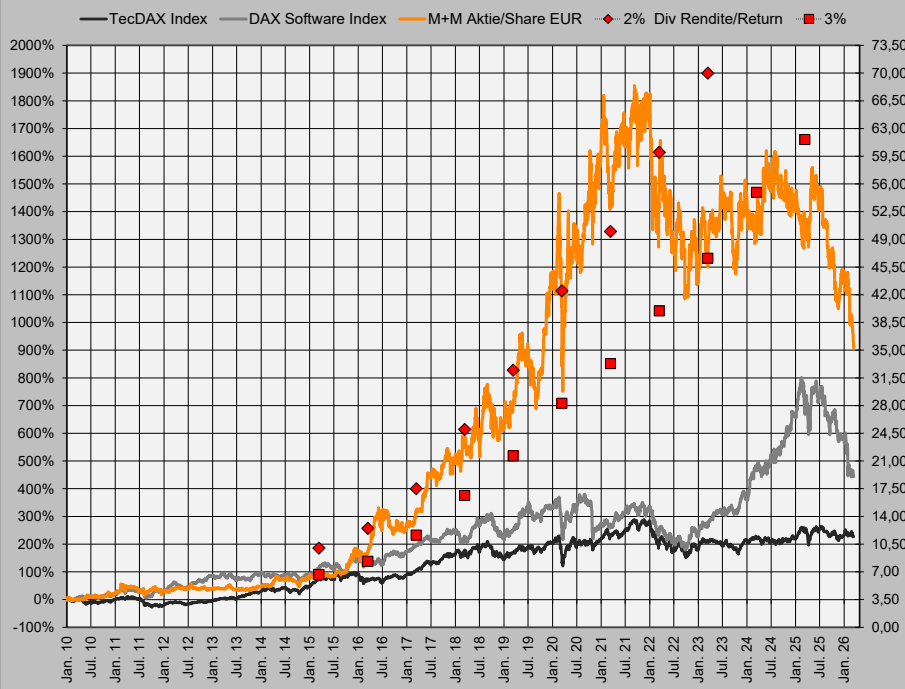

The M+M share price augmented significantly since 2010. In addition, dividends of EUR 10.60 were distributed during this period. The price performance corresponded to that of the TecDAX and DAX Software until 2015, but since then the M+M share has had a big lead and has more or less moved within an initial dividend yield of 2-3% since, with deviations down to 1.5% during Corona 2020/21 and up to more than 5% in the years since 2022. By the way: Anyone who has invested EUR 1,000 a month in the M+M share since August 1997, i.e. one month after the IPO, had already received 147% of the total investment of KEUR 341 in dividends by Dec 31, 2025 and was able to enjoy a total value before taxes of KEUR 2,590, i.e. 7.6 times the stake.

❖ Statement of income						
Amounts in KEUR	Note*	2025		△%	2024	
Revenues	1	238,587	100%	-27%	325,844	100%
Cost of materials	2	-56,710	-23.8%	-62.5%	-151,254	-46.4%
Gross profit		181,877	76.2%	+4.2%	174,590	53.6%
Personnel expenses	3	-110,363	-46.3%	+5.3%	-104,810	-32.2%
Other operating expenses	4	-21,283	-8.9%	-4.2%	-22,212	-6.8%
Other operating income	6	10,186	4.3%	+11%	9,170	2.8%
Operating result EBITDA		60,417	25.3%	+6.5%	56,738	17.4%
Depreciation	5	-4,209	-1.8%	+6.2%	-3,963	-1.2%
Depreciation finance leasing (IFRS 16)	5	-6,585	-2.8%	+14%	-5,783	-1.8%
Amortisation PPA	5	-517	-0.2%	0%	-517	-0.2%
Operating result EBIT		49,106	20.6%	+5.7%	46,475	14.3%
Financial result	7	-2,044	-0.9%	+117%	-942	-0.3%
Result before taxes		47,062	19.7%	+3.4%	45,533	14.0%
Taxes on income	8	-12,160	-5.1%	+0.5%	-12,098	-3.7%
Net result after taxes		34,902	14.6%	+4.4%	33,435	10.3%
thereof attributable to M+M shareholders		31,811	13.3%	+4.3%	30,487	9.4%
thereof attributable to minority shareholders		3,091	1.3%	+4.9%	2,948	0.9%
Net income per share in EUR	9	1.9091		+5.9%	1.8031	
Weighted average shares outstanding in million		16.663		-1.4%	16.908	

*see notes on pages 48 to 50

❖ Consolidated statement of comprehensive income						
Amounts in KEUR		2025			2024	
Net result after taxes		34,902			33,435	
thereof attributable to M+M shareholders		31,811			30,487	
thereof attributable to minority shareholders		3,091			2,948	
Currency conversion difference		-494			196	
Other comprehensive income that may be reclassified subsequently to profit or loss		-494			196	
Actuarial gains / losses on pension obligations		88			68	
Deferred taxes thereof		-39			-20	
Other comprehensive income that will not be reclassified subsequently to profit or loss		49			48	
Total other result		-445			244	
Total comprehensive income		34,457			33,679	
thereof attributable to M+M shareholders		31,366			30,731	
thereof attributable to minority shareholders		3,091			2,948	

 Balance sheet

Amounts in KEUR	Note*	Dec 31, 2025	△%	Dec 31, 2024
Cash and cash equivalents		15,760	-63%	42,997
Trade accounts receivable	10	41,931	+19%	35,171
Inventories	11	7,819	-7%	8,436
Prepaid expenses and other current assets	12	10,562	-23%	13,668
Total current assets		76,072 37,8%	-24%	100,272 47,3%
Property, plant and equipment		5,516	+2%	5,416
Real estate		16,923	-2%	17,319
Intangible assets		33,838	+20%	28,247
Goodwill	13	47,874	0%	47,874
Other investments		98	+206%	32
Rights to use leasing contracts (IFRS 16)	14	13,469	+18%	11,418
Deferred taxes	8	1,363	+4%	1,314
Non current trade accounts receivable	10	6,011		0
Total non current assets		125,092 62,2%	+12%	111,620 52,7%
Total assets		201,164 100%	-5%	211,892 100%
Short term debt and current portion of long term debt	15	10,597	+252%	3,013
Current finance lease obligations (IFRS 16)	14	6,125	+19%	5,162
Trade accounts payable		26,783	-20%	33,414
Accrued expenses	16	13,228	+7%	12,405
Deferred revenues		6,823	+10%	6,184
Income tax payable		5,225	+6%	4,938
Other current liabilities	17	6,990	-2%	7,147
Total current liabilities		75,771 37,7%	+5%	72,263 34,1%
Long term debt, less current portion	18	25,185	+453%	4,558
Long term finance lease obligations (IFRS 16)	14	7,508	+17%	6,399
Non current trade accounts payable	19	280	-98%	16,293
Deferred taxes	8	7,584	+4%	7,299
Pension accruals	20	0	-100%	85
Other accruals	16	80	0%	80
Total non current liabilities		40,637 20,2%	+17%	34,714 16,4%
Share capital	21	17,149	0%	17,149
Capital reserve and other reserves	22	49,422	+0%	49,299
Treasury stock	23	-32,336	+176%	-11,726
Retained earnings / accumulated deficit		43,411	+3%	42,272
Other comprehensive income / loss		-381	-11%	-430
Equity attributable to non-controlling (minority) interest		6,090	-6%	6,455
Currency conversion		1,401	-26%	1,896
Total shareholders' equity		84,756 42,1%	-19%	104,915 49,5%
Total liabilities and shareholders' equity		201,164 100%	-5%	211,892 100%

* see notes on pages 49, 51 to 57

Statement of cash flows Development of shareholders' equity

❖ Statement of cash flows		
Amounts in KEUR	2025	2024
Net profit	34,902	33,435
Interest result	298	-144
Depreciation and amortization	11,311	10,263
Other non cash income / expenses	948	2,470
Increase/decrease in provisions and accruals	832	-847
Gains/losses from the disposal of fixed assets	-123	-36
Change in net working capital	-31,588	17,177
Net cash provided by (used in) operating activities	16,580	62,318
Purchase of subsidiaries, net of cash	-1,057	-749
Purchase of real estate	-15	-20
Purchase of other fixed assets	-10,271	-10,300
Sale of other fixed assets	294	136
Net cash provided by (used in) investing activities	-11,049	-10,933
Proceeds from issuance of share capital	1,061	2,606
Interest proceeds/payments	-322	6
Purchase/disposal of treasury stock	-20,610	518
Dividend payment to M+M shareholders	-30,672	-27,771
Dividend payment to minority shareholders	-3,365	-3,117
Proceeds from short or long term borrowings	28,221	-1
Change in finance lease obligations IFRS 16	-6,564	-5,781
Net cash provided by (used in) financing activities	-32,251	-33,540
Net effect of currency translation in cash and cash equivalents	-517	285
Net increase / decrease in cash and cash equivalents	-27,237	18,130
Cash and cash equivalents at beginning of period	42,997	24,867
Cash and cash equivalents at end of period	15,760	42,997

see notes on page 58

❖ Development of shareholders' equity									
Amounts in KEUR	Subscribed Capital	Capital Reserve	Profit/Loss	Other comprehensive income/loss	Treasury stock	Currency conversion	attributable to M+M SE shareholders	Minority interest	Total equity
As of Dec 31, 2023	17,149	47,160	39,556	-577	-12,244	1,807	92,849	6,906	99,757
Treasury stock		148			-6,318		-6,170		-6,170
Dividend		2,457	-27,771		6,836		-18,478	-3,117	-21,595
Net result			30,487				30,487	2,948	33,435
Minority interest change		-466					-466	-282	-748
Other comprehensive income from pension assessment				47			47		47
Currency conversion				100		89	189		189
As of Dec 31, 2024	17,149	49,299	42,272	-430	-11,726	1,896	98,458	6,455	104,915
Treasury stock		-122			-30,429		-30,551		-30,551
Dividend		1,184	-30,672		9,819		-19,669	-3,365	-23,034
Net result			31,811				31,811	3,091	34,902
Minority interest change		-939					-939	-91	-1,030
Other comprehensive income from pension assessment				49			49		49
Currency conversion						-495	-495		-495
As of Dec 31, 2025	17,149	49,422	43,411	-381	-32,336	1,401	78,664	6,090	84,756

Notes

Segment reporting

According to IFRS 8, reportable operating segments are identified based on the 'management approach'. This approach stipulates external segment reporting based on the Group's internal organizational and management structure and on internal financial reporting to the chief operating decision maker.

The measurement principles for the segment reporting structure are based on the IFRS principles adopted in the consolidated financial statements. M+M evaluates the segments' performance based on their profit/loss from operations (EBIT), among other factors. Revenue generated and goods and services exchanged between segments are calculated on the basis of market prices.

Segment assets and liabilities include all assets and liabilities that are attributable to operations and whose positive or negative results determine profit/loss from operations. Segment assets include, in particular, intangible assets; property, plant and equipment; trade and other receivables; and inventories. Segment liabilities include, in particular, trade and other payables, and significant provisions.

Segment investments include additions to intangible assets and property, plant and equipment. Deferred tax assets and liabilities are not included in the segment assets and segment liabilities.

The M+M business model is divided into the two segments M+M Software and M+M Digitization (formerly VAR Business). The Software segment includes the sales and marketing of self-developed CAD/CAM/CAE/BIM software.

The Digitization segment includes the development of customer-specific software solutions, the resale or agency against commission of third-party software and hardware as well as related services.

The sum of the operating results (EBIT), determined at the level of the segments, agrees with the operating result in the statement of income. The financial result and the taxes on income are not controlled at segment level. Therefore the representation of reconciliation to the net result after taxes is not shown.

According to the regulations of IFRS 8 the revenues are also differentiated in Germany, the domicile of Mensch und Maschine Software SE, and business in foreign countries.



❖ Segmentation										
Amounts in KEUR	M+M Software						M+M Digitization*			
	2025		△%	2024		2025		△%	2024	
Revenue	114,474	100%	+4.7%	109,316	100%	124,113	100%	-43%	216,527	100%
share in percent	48.0%			33.5%		52.0%			66.5%	
Cost of materials	-11,738	-10.3%	+14%	-10,291	-9.4%	-44,972	-36.2%	-68%	-140,963	-65.1%
Gross profit	102,736	89.7%	+3.7%	99,025	90.6%	79,141	63.8%	+4.7%	75,565	34.9%
share in percent	56.5%			56.7%		43.5%			43.3%	
Personnel expenses	-57,294	-50.0%	+4.4%	-54,870	-50.2%	-53,069	-42.8%	+6.3%	-49,940	-23.1%
Other operating expenses	-13,011	-11.4%	+3.8%	-12,531	-11.5%	-8,272	-6.7%	-15%	-9,681	-4.5%
Other operating income	5,250	4.6%	+46%	3,605	3.3%	4,936	4.0%	-11%	5,565	2.6%
Depreciation	-2,020	-1.8%	+4.9%	-1,925	-1.8%	-2,189	-1.8%	+7.4%	-2,038	-0.9%
Depreciation Leasing (IFRS 16)	-2,746	-2.4%	+25%	-2,199	-2.0%	-3,839	-3.1%	+7.1%	-3,584	-1.7%
Amortisation purchase price allocation PPA	-517	-0.5%	0%	-517	-0.5%	0	0.0%		0	0.0%
Operating result EBIT	32,398	28.3%	+5.9%	30,588	28.0%	16,708	13.5%	+5.2%	15,887	7.3%
share in percent	66.0%			65.8%		34.0%			34.2%	
Segment assets	82,180			80,355		117,622			130,222	
Fixed assets	49,655			49,293		74,075			61,012	
Investments	4,335			3,932		5,981			6,387	
Liabilities	25,987			26,773		86,456			77,735	

*former segment name: VAR Business

❖ Geographical segmentation				
Amounts in KEUR	2025		2024	
	Germany	International	Germany	International
External revenue	100,601	137,986	138,460	187,384
share in percent	42.2%	57.8%	42.5%	57.5%
Fixed assets	85,395	38,335	79,601	30,704
Investments	9,566	750	9,704	615

General remarks

Basis of the group financial statements

The consolidated financial statements of Mensch und Maschine Software SE, Wessling, Germany have been drawn up in compliance with International Financial Reporting Standards (IFRS) according to the specifications as defined in the currently valid guidelines of the International Accounting Standards Board (IASB). All IFRS and International Accounting Standards (IAS) as well as the interpretations of the International Financial Reporting Interpretations Committee (IFRIC) or the former Standing Interpretations Committee (SIC) which have been in effect at the closing date, and accepted by the EU, have been considered.

In addition to that, the regulations of Article 315e of the German Commercial Code and §160 of the German Stock Corporation Act have been considered.

M+M SE is a global enterprise based in Germany, headquartered at Argelsrieder Feld 5, 82234 Wessling and registered in the Commercial Register of the Munich Local Court under the number HRB 165230. Its business activities are focused on technical software.

The Managing Directors of M+M SE approved the consolidated financial statements on February 27, 2026 for submission to the company's Administrative Board.

The Administrative Board approved the consolidated financial statements at its meeting on March 12, 2026 and approved for publication on March 17, 2026.

The consolidated financial statements have been prepared in Euros. Unless otherwise specified, all amounts are stated in thousand Euros (KEUR).

These consolidated financial statements were prepared for the 2025 fiscal year (January 1 to December 31).

Changes in accounting policies

The IASB has approved a number of changes to the existing IFRS and adopted several new IFRS, which became effective as of January 1, 2025. M+M is applying the following IFRSs in the reporting period for the first time:

IAS 21 The Effects of Changes in Foreign Exchange Rates: Lack of Exchangeability

The application of these changes had no material impact on the M+M consolidated financial statements.

New accounting policies

The IASB and IFRIC have adopted further standards and interpretations, which were endorsed by the European Union but not yet effective in the 2025 financial year:

IFRS 7 / IFRS 9

Amendments to the Classification and Measurement of Financial Instruments

IFRS 7 / IFRS 9

Contracts Referencing Nature-dependent Electricity

IFRS 18 Presentation and Disclosure in Financial Statements

IAS 7, IFRS 1, IFRS 7, IFRS 9 and IFRS 10

Annual Improvements to IFRS Accounting Standards - Volume 11

The following standards and interpretations have not yet been endorsed by the European Union:

IFRS 19 Subsidiaries without Public Accountability: Disclosures

IAS 21 The Effects of Changes in Foreign Exchange Rates: Translation to a Hyperinflationary Presentation Currency

These Standards and Interpretations have to be applied for annual periods beginning after January 1, 2026. These regulations have not been early adopted by the M+M group.

The application of these standards is not expected to have a material impact on the Group's financial statement 2026.

The effects of IFRS 18, which have to be applied for annual periods beginning after January 1, 2027, are currently being determined.

Valuation methods and accounting policies applied

Consolidated companies and closing date

In addition to the parent company, the consolidated financial statement comprises all directly and indirectly owned domestic and international subsidiaries, at which M+M SE holds directly or indirectly the majority of the voting rights or the control of the economic power, which are included in accordance with the principles of full consolidation. They are deconsolidated when the parent ceases to have control. The balance sheet closing date for nearly all subsidiaries included in the group consolidated financial statement is December 31. For subsidiaries with different fiscal years, interim financial statements are prepared.

In addition to the parent company, the following companies were fully consolidated in the group financial statements of December 31, 2025:

In fiscal year 2025, the percentage ownership of the subsidiary Mensch und Maschine Scholle GmbH, Velbert, Germany was increased from 87.5% to 100%. In accordance with IFRS 3 (Business combinations after January 1, 2010) the expected purchase price liability was recorded in equity by KEUR 64.

Furthermore, the percentage ownership of the subsidiary Mensch und Maschine acadGraph GmbH, Munich, Germany was increased from 93.4% to 100% in fiscal year 2025. In accordance with IFRS 3 (Business combinations after January 1, 2010) the expected purchase price liability was recorded in equity by KEUR 874.

❖ M+M group consolidated companies

Mensch und Maschine Management AG, Wessling, Germany	100%	OPEN MIND Technologies AG, Wessling, Germany	100%
Mensch und Maschine Deutschland GmbH, Wessling, Germany	100%	and shareholdings:	
Mensch und Maschine Infrastruktur GmbH, Stuttgart, Germany	70%	OPEN MIND Technologies USA Inc., Needham, MA, USA	100%
Mensch und Maschine At Work GmbH, Bissendorf, Germany	100%	OPEN MIND Technologies Asia Pacific Ltd., Singapore	100%
customX GmbH, Hadamar, Germany	58.1%	OPEN MIND Technologies S.r.l., Rho, Italy	100%
Mensch und Maschine Scholle GmbH, Velbert, Germany	100%	OPEN MIND CAD-CAM Technologies S.r.l., Rho, Italy	100%
Mensch und Maschine acadGraph GmbH, München, Germany	100%	OPEN MIND Technologies France S.a.r.l., Limas, France	100%
Mensch und Maschine Schweiz AG, Winkel (Zürich), Switzerland	100%	OPEN MIND Technologies Japan Inc., Tokyo, Japan	100%
Mensch und Maschine Austria GmbH, Großwilfersdorf, Austria	100%	OPEN MIND Technologies Portugal, Marinha Grande, Portugal	100%
Man and Machine France S.a.r.l., Paris, France	100%	OPEN MIND Technologies UK Limited, Bicester, UK	100%
Man and Machine Software s.r.l., Vimercate (Mailand), Italy	100%	OPEN MIND Technologies China Co.Ltd, Shanghai, China	100%
Man and Machine Software Sp. z o.o., Lodz, Poland	100%	OPEN MIND Technologies Taiwan Inc., New Taipei City, Taiwan	100%
Man and Machine Ltd., Thame, UK	100%	OPEN MIND Technologies Schweiz GmbH, Wängi, Switzerland	100%
Man and Machine Romania SRL, Bukarest, Romania	100%	OPEN MIND CAD-CAM Technologies India Private Ltd, Bangalore, India	100%
Mensch und Maschine Hungary Kft, Sopron, Hungary	50.1%	OPEN MIND Technologies Spain S.L., Valencia, Spain	100%
Mensch und Maschine Medienzentrum AG, Wessling, Germany	99.7%	OPEN MIND Technologia Brasil LTDA, Sao Paulo, Brasil	100%
Mensch und Maschine Mechatronik GmbH, Donzdorf, Germany	100%	OPEN MIND Technologies Benelux BV, Hertogenbosch, Netherlands	100%
		OPEN MIND Technologies Scandinavia AB, Göteborg, Sweden	100%
SOFISTIK AG, Oberschleissheim, Germany	51.4%	OPEN MIND Technologies Korea Ltd., Seoul, South Korea	100%
and shareholdings:		Hummingbird Systems GmbH, Herzogenaurach, Germany	51%
BiMOTION GmbH, Nürnberg, Germany	51%		
SOFISTIK North America Corp., New York, USA	100%	DATAflor Software AG, Göttingen, Germany	67.2%
SOFISTIK ME LTD, Tel Aviv, Israel	51%		
SOFIN Consulting Ltd., Espo, Finland	51%		
SOFISTIK India Privat Limited, Delhi, India	100%		

Other remarks

The financial statements of all group companies were drawn up on the basis of common accounting principles. As far as there is an obligation to examine, they are audited by independent auditors and endorsed by an unqualified audit opinion.

The following domestic subsidiaries made use in 2025 of certain exemptions granted under Sections 264, paragraph 3 of the German Commercial Code regarding the management report and release from the publication of financial statements:

- Mensch und Maschine Management AG, Wessling, Germany
- Mensch und Maschine Deutschland GmbH, Wessling, Germany
- OPEN MIND Technologies AG, Wessling, Germany

Principles of consolidation

The consolidated financial statements include subsidiaries. Subsidiaries are companies over which M+M is currently able to exercise power by virtue of existing rights. Power means the ability to direct the activities that significantly influence a company's profitability. Control is therefore only deemed to exist if M+M is exposed, or has rights, to variable returns from its involvement with a company and has the ability to use its power over that company to affect the amount of that company's returns. The ability to control another company generally derives from M+M direct or indirect ownership of a majority of the voting rights.

Inclusion of an entity's accounts in the consolidated financial statements begins when the Group is able to exercise control over the entity and ceases when it is no longer able to do so.

Business combinations after January 1, 2010 are accounted for using the acquisition method. The cost of an acquisition is measured as the aggregate of the consideration transferred, measured at acquisition date fair value and the amount of any non-controlling interest in the acquiree. For each business combination, the acquirer measures the non-controlling interest in the acquiree either at fair value or at the proportionate share of the acquiree's identifiable net assets.

Acquisition costs incurred are expensed and included in administrative expenses.

When the Group acquires a business, it assesses the financial assets and liabilities assumed for appropriate classification and designation in accordance with the contractual terms, economic circumstances and pertinent conditions as at the acquisition date. This includes the separation of embedded derivatives in host contracts by the acquiree.

If the business combination is achieved in stages, the acquisition date fair value of the acquirer's previously held equity interest in the acquiree is remeasured to fair value at the acquisition date through profit or loss.

Any contingent consideration to be transferred by the acquirer will be recognized at fair value at the acquisition date.

The purchase of shares (participation rate increase) after the initial consolidation is accounted for as an equity transaction.

Subsequent changes to the fair value of the contingent consideration which is deemed to be an asset or liability will be recognized in accordance with IAS 39 either in profit or loss or as a change to other comprehensive income. If the contingent consideration is classified as equity, it should not be remeasured until it is finally settled within equity.

Goodwill is initially measured at cost being the excess of the aggregate of the consideration transferred and the amount recognized for non-controlling interest over the net identifiable assets acquired and liabilities assumed. If this consideration is lower than the fair value of the net assets of the subsidiary acquired, the difference is recognized in profit or loss.

After initial recognition, goodwill is measured at cost less any accumulated impairment losses. For the purpose of impairment testing, goodwill acquired in a business combination is, from the acquisition date, allocated to each of the Group's cash-generating units that are expected to benefit from the combination, irrespective of whether other assets or liabilities of the acquiree are assigned to those units.

Where goodwill forms part of a cash-generating unit and part of the operation within that unit is disposed of, the goodwill associated with the operation disposed of is included in the carrying amount of the operation when determining the gain or loss on disposal of the operation.

Goodwill disposed of in this circumstance is measured based on the relative values of the operation disposed of and the portion of the cash-generating unit retained.

For business combinations prior to January 1, 2010 in comparison to the above-mentioned requirements, the following differences applied:

Business combinations were accounted for using the purchase method. Transaction costs directly attributable to the acquisition formed part of the acquisition costs. The non-controlling interest (formerly known as minority interest) was measured at the proportionate share of the acquiree's identifiable net assets.

Business combinations achieved in stages were accounted for as separate steps. Any additional acquired share of interest did not affect previously recognized goodwill.

When the Group acquired a business, embedded derivatives separated from the host contract by the acquiree were not reassessed on acquisition unless the business combination resulted in a change in the terms of the contract that significantly modified the cash flows that otherwise would have been required under the contract.

Contingent consideration was recognized if, and only if, the Group had a present obligation, the economic outflow was more likely than not and a reliable estimate was determinable.

Subsequent adjustments to the contingent consideration were recognized as part of goodwill.

The differences arising from the consolidation of capital, to the extent that they are assets, are indicated as goodwill under non-current assets.

Non-controlling interests are valued at closing time with their share in shareholders' equity respective earnings of the year of the particular subsidiary.

Receivables, reserves, liabilities, accruals and deferrals resulting from intra-group transactions are mutually offset. Differences from the consolidation of debt are treated with effect on earnings.

Contingent liabilities were consolidated to the required extent. Interim profits and losses resulting from intra-group supply and service trading were likewise eliminated as were investment returns from companies included in the consolidation. Intra-group sales revenues as well as other intra-group earnings were offset by the appropriate expenditures.

With regard to the consolidation measures affecting results, tax deferrals pursuant to IAS 12 were carried out to the extent that the deviation in tax expenditure would conceivably be balanced in future fiscal years.

Management judgements in the application of accounting policies

The presentation of the results of operations, financial position or cash flows in the consolidated financial statements is dependent upon and sensitive to the accounting policies, assumptions and estimates. The actual amounts may differ from those estimates.

The following critical accounting estimates and related assumptions and uncertainties inherent in accounting policies applied are essential to understand the underlying financial reporting risks and the effects that these accounting estimates, assumptions and uncertainties have on the consolidated financial statements.

Measurement of property, plant and equipment, and intangible assets involves the use of estimates for determining the fair value at the acquisition date, in particular in the case of such assets acquired in a business combination. Furthermore, the expected useful lives of these assets must be estimated. The determination of the fair values of assets and liabilities, as well as of the useful lives of the assets is based on management's judgement.

The determination of impairments of property, plant and equipment as well as intangible assets involves the use of estimates that include, but are not limited to, the cause, timing and amount of the impairment.

Impairment is based on a large number of factors, such as changes in current competitive conditions, expectations of growth, increased cost of capital, changes in the future availability of financing, technological obsolescence, discontinuance of services, current replacement costs, prices paid in comparable transactions and other changes in circumstances that indicate an impairment exists. The recoverable amount and the fair values are typically determined using a discounted cash flow method which incorporates reasonable market participant assumptions.

The identification of impairment indicators, as well as the estimation of future cash flows and the determination of fair values for assets require management to make significant judgements concerning the identification and validation of impairment indicators, expected cash flows, applicable discount rates, useful lives and residual values.

If the demand for these products and services does not materialize as expected, this would result in less revenue, less cash flow and potential impairment to write down these investments to their fair values, which could adversely affect future operating results.

The determination of the recoverable amount of a cash-generating unit involves the use of estimates by management. To determine the fair value less costs to sell include discounted cash flow-based methods.

Key assumptions on which management has based its determination of fair value less costs to sell include earning development, capital expenditure and market share. These estimates, including the methodologies used, can have a material impact on the fair value and ultimately the amount of any goodwill impairment.

Management maintains an allowance for doubtful accounts to account for estimated losses resulting from the inability of customers to make required payments. When evaluating the adequacy of an allowance for doubtful accounts, management bases its estimates on the aging of accounts receivable balances and historical write-off experience, customer credit worthiness and changes in customer payment terms.

If the financial condition of customers were to deteriorate, actual write offs might be higher than expected.

Income taxes must be estimated for each of the jurisdictions in which the Group operates, involving a specific calculation of the expected actual income tax exposure for each tax object and an assessment of temporary differences resulting from the different treatment of certain items for IFRS consolidated financial and tax reporting purposes. Any temporary differences will generally result in the recognition of deferred tax assets and liabilities in the consolidated financial statements. Management judgement is required for the calculation of actual and deferred taxes.



Deferred tax assets are recognized to the extent that their utilization is probable. The utilization of deferred tax assets will depend on whether it is possible to generate sufficient taxable income in the respective tax type and jurisdiction, taking into account any legal restrictions on the length of the loss carry-forward period. Various factors are used to assess the probability of the future utilization of deferred tax assets, including past operating results, operational plans, loss carry forward periods, and tax planning strategies.

If actual results differ from these estimates or if these estimates must be adjusted in future periods, the financial position, results of operations and cash flows may be negatively affected. In the event that the assessment of future utilization of deferred tax assets changes, the recognized deferred tax assets must be reduced and this reduction be recognized in profit or loss. The only tax loss carry forwards capitalized by M+M are those which can presumably be used within the following five years.

Pension obligations for benefits are generally satisfied by plans which are classified and accounted for as defined benefit plans. Pension benefit costs are determined in accordance with actuarial valuation, which rely on assumptions including discount rates, life expectancies and expected return on plan assets. In the event that further changes in assumptions are required with respect to discount rates and expected returns on invested assets, the future amounts of the pension benefit costs may be affected materially.

The Management exercises considerable judgment in measuring and recognizing provisions and the exposure to contingent liabilities related to litigation or outstanding claims subject to negotiated settlement, mediation, arbitration or government regulation, as well as other contingent liabilities. Judgment is necessary in assessing the likelihood that a claim will succeed, or a liability will arise, and to quantify the possible range of the final settlement.

Provisions are recorded for liabilities when losses are expected from pending contracts, a loss is considered probable and can be reasonably estimated. Because of the inherent uncertainties in this evaluation process, actual losses may be different from the originally estimated provision.

In addition, significant estimates are involved in the determination of provisions related to taxes and litigation risks. These estimates are subject to change as new information becomes available, primarily with the support of internal specialists, if available, or with the support of outside consultants, such as actuaries or legal counsel. Revisions to the estimates of these losses from executory contracts may significantly affect future operating results.

Currency conversion

The annual financial statements of the group's international subsidiaries were converted into Euro in accordance with the principle of functional currency in compliance with IAS 21.

This refers to the respective national currency for all companies since these international companies are financially, economically and organizationally independent with respect to their operations. Accordingly, equity was converted at the historical exchange rate, the other balance sheet items were converted

at the exchange rate on closing date, and income and expenditures as well as year end results were converted using a mean exchange rate for the year. In compliance with IAS 21, differences arising from currency conversion of both capital consolidation and transfer of the annual earnings to the balance sheet at the mean annual exchange rate were treated as having no effect on earnings and are included within equity. Newly acquired Goodwill is translated as an asset of the economically autonomous foreign entity at the exchange rate in effect on the balance sheet date.

Exchange rates

	Average		Year end	
	2025	2024	Dec 31, 2025	Dec 31, 2024
1 Swiss Franc	1.0671	1.0498	1.0737	1.0625
1 Pound Sterling	1.1674	1.1812	1.1460	1.2060
1 Polish Zloty	0.2359	0.2322	0.2369	0.2339
1 Swedish Krona	0.0904	0.0875	0.0924	0.0873
1 Romania Ron	0.1984	0.2010	0.1962	0.2010
1 US Dollar	0.8855	0.9242	0.8511	0.9626
1 Singapore Dollar	0.6779	0.6917	0.6620	0.7060
100 Japanese Yen	0.5919	0.6104	0.5432	0.6133
1 Taiwan Dollar	0.0272	0.0295	0.0272	0.0295
1 Renminbi Chinese Yuan	0.1232	0.1284	0.1216	0.1319
1 India Rupie	0.0102	0.0110	0.0095	0.0112
1 Brazil Real	0.1586	0.1716	0.1554	0.1556
1 Hungarian Forint	0.0025	0.0025	0.0026	0.0024
1 Israeli Schekel	0.2569	0.2497	0.2669	0.2640
1 South Korean Won	0.0006		0.0006	

Structure of statement of income and balance sheet

In keeping with the international practice of consolidated financial statements, the report begins with the statement of income (profit and loss), itemized according to the nature of expense method.

In accordance with IAS 1, the balance sheet is apportioned into current and non-current assets and into current and non-current liabilities. Assets and liabilities are regarded as current if they mature within one year.

Accounting and valuation methods

Cash and cash equivalent

M+M shows credit balances at banks under cash and cash equivalents. Foreign currency credit balances are converted by exchange rate at closing date.

Property, plant and equipment

Property, plant and equipment is reported at cost of acquisition less regular depreciation. These assets are depreciated over the useful economic life of 3 to 50 years.

Business combinations

Business combinations are accounted for using the purchase method. Goodwill on acquisition is initially measured at cost being the excess of the cost of the business combination over the acquirer's interest in the net fair value of the identifiable assets, liabilities and contingent liabilities. Following initial recognition, goodwill is measured at cost less any accumulated impairment losses.

According to IFRS 3 (business combinations) goodwill is not amortized, instead it is subjected to an impairment test, at least once every year.

In the context of the impairment test, the recoverable amount of the cash generating units is determined by the current value less sales costs or the value in use. The individual subsidiaries of M+M were defined as cash generating units.

The current value reflects the best estimation of the amount, for which an independent third party would acquire the cash generating units as of balance-sheet date.

Sale costs are taken off. The value in use is determined on the basis of DCF methods.

To calculate this, cash flow projections are based on financial budgets approved by the Administrative Board covering a five-year period. This planning is based on experiences from the past as well as on expectations over the future market development.

The discount rate is determined on the basis of market data and considers credit and market risks. For the cash generating units the after-tax basis discount rate amounts between 7.49% and 11.73%.

If this results in the carrying amount of a cash-generating unit to which goodwill was allocated exceeding the recoverable amount, the allocated goodwill is initially written down by the difference.

Impairment losses which must be recognized in addition to this are taken into account by reducing the carrying amount of the other assets of the cash-generating unit on a prorated basis. If the reason for an impairment loss recognized in prior years has ceased to exist, a write-back is performed, whereby the increased carrying amount resulting from the write-back may not exceed the amortized cost. Impairment losses on goodwill are not reversed.

Other intangible assets

Intangible assets are reported at cost of acquisition less regular depreciation. These assets are depreciated over the useful economic life of 3 to 15 years and are included in the depreciation.

Intangible assets, acquired in the context of a business combination, are capitalized at fair value as at the date of acquisition. Following initial recognition, the cost model is applied to the class of intangible assets. The useful lives of these intangible assets are assessed to be either finite or indefinite. Where amortisation is charged on assets with finite lives, the useful economic life is up to 15 years.

The amortization period for an intangible asset with a finite useful life is reviewed regularly. The expense for the amortization is taken to the income statement through the amortizations.

Intangible assets with an indefinite useful life are tested for impairment once a year at the cash-generating unit level. Intangible assets created within the business are not capitalized and expenditure is charged against profits in the year in which the expenditure is incurred. Development expenditure on an individual project is capitalized if their future recoverability can reasonably be regarded as assured.

Research costs are expensed as incurred.

Financial instruments

A financial instrument is a contract that gives rise to both a financial asset of one entity and a financial liability or equity instrument of another entity.

Financial assets

Since January 1, 2018, the Group classifies its financial assets into the following evaluation categories:

- those subsequently measured at fair value (either directly in equity or through profit or loss), and
- those measured at amortized cost.

The classification is dependent on the company's business model for managing financial assets and on the contractual cash flows. In the case of assets measured at fair value, gains and losses are recognised either in profit or loss or directly in equity. For investments in equity instruments that are not held for trading, this depends on whether the Group has irrevocably decided at the time of initial recognition to measure the equity instruments at fair value through equity.

A normal market purchase or sale of financial assets is recognised on the trade date, i.e. the date on which the Group undertakes to buy or sell the asset. Financial assets are derecognised when the rights to receive cash flows from the financial assets have expired or have been transferred and the Group has transferred substantially all risks and rewards of ownership. On initial recognition, the Group measures a financial asset at fair value plus, in the case of a subsequent financial asset not measured at fair value through profit or loss, the transaction costs directly attributable to the acquisition of that asset. Transaction costs of financial assets at fair value through profit or loss are recognised as an expense in profit or loss.

Subsequent measurement depends on the Group's business model for managing the asset and the cash flow characteristics of the asset:

- About amortized costs:

Assets that are held to collect the contractual cash flows, and for which these cash flows represent exclusively interest and principal payments, are measured at amortized cost. Interest income from these financial assets is reported under financial income using the effective interest method. Gains or losses from derecognition are recorded directly in the income statement.

- Financial assets assessed at fair value through profit or loss:
Assets that are held to collect the contractual cash flows and sell the financial assets, and for which the cash flows represent exclusively interest and principal payments, are measured at fair value through equity. Changes in the carrying amount are recognised in other comprehensive income, except for impairment gains or losses, interest income and foreign exchange gains or losses that are recognised in profit or loss. When the financial asset is derecognised, the cumulative gain or loss previously recognised in other comprehensive income is reclassified from equity to profit or loss and recognised in other operating income/expense. Interest income from these financial assets is reported under financial income using the effective interest method.

- Financial assets assessed at fair value through profit or loss:
Assets that do not meet the other criteria are classified as at fair value through profit or loss and gains or losses are recognised in other operating income/expense in the period in which they arise.

Since January 1, 2018, the Group assesses on a forward-looking basis the expected credit losses associated with its assets measured at amortized cost or at fair value through profit or loss. The impairment method depends on whether there is a significant increase in credit risk.

In the case of trade receivables, the Group applies the simplified approach permitted by IFRS 9, according to which expected credit losses over the term are to be recognised from the initial recognition of the receivables.

Leases

M+M assesses at the beginning of the contract whether a contract constitutes or contains a lease. This is the case if the contract entitles to control the use of an identified asset against payment of a fee for a certain period of time.

Since January 1, 2019, the group as a lessee recognizes in general for all leases within the statement of financial position an asset for the right of use of the leased assets and a liability for the lease payment commitments at present value.

These are primarily rentals of property and buildings, technical equipment and machinery, other plants and operating and office equipment. The right of use assets reported under property, plant and equipment are recognized at cost less accumulated depreciation and impairment losses. Payments for non-lease components are not included in the determination of the lease liability. The lease liabilities reported under financial liabilities reflect the present value of the outstanding lease payments at the time the asset is made available for use. Lease payments are discounted at the interest rate implicit in the lease if it can be readily determined. Otherwise, they are discounted at the lessee's incremental borrowing rate.

The derivation of the interest rate is based on the assumption that an adequate amount of funds will be raised over an adequate period of time in the amount of an asset comparable to the right of use asset, taking into account the economic environment and comparable collateral.

The lease liabilities include the following lease payments:

- Fixed payments, less lease incentives to be paid by the lessor;
- variable lease payments that are based on an index or an interest rate;
- expected amounts to be payable by the lessee under residual value guarantees;
- the exercise price of a purchase option, if the exercise is reasonably certain and
- payment of penalties for the termination of the lease, if the lease term reflects the lessee exercising an option to terminate the lease.

Right-of-use assets are measured at cost, which are comprised as follows:

- Lease liability,
- lease payments made at or before the commencement date less any lease incentives received,
- initial direct costs, and
- dismantling obligations.

Subsequent measurement is performed at amortized cost. Right-of-use assets are depreciated on a straight-line basis over the lease term, unless the useful life of the underlying asset is shorter. If the lease agreement contains reasonably certain purchase options, the right of use is depreciated over the economic life of the underlying asset.

In subsequent measurement, the lease liability is compounded, and the corresponding interest expense is recognized in the financial result. The lease payments made reduce the carrying amount of the lease liability.

In accordance with the recognition exemptions, low-value leases of and short-term leases (less than twelve months) are recognized in the statement of income. Only leased assets with a value of up to €5,000 are classified as low-value leased assets. Furthermore, the new regulations are not applied to leases of intangible assets.

For contracts comprising a non-lease component as well as a lease component, each lease component must be accounted for separately from non-lease component as a lease.

The lessee must allocate the contractually agreed-upon payment to the separate lease components based on the relative standalone selling price of the lease component and the aggregated standalone selling price of the non-lease components.

The term of the lease is determined based on the non-cancellable lease term. Especially real estate leases contain extension and termination options. Such contractual conditions offer the greatest possible operational flexibility to the Group. In determining the lease term, all facts and circumstances are considered that provide an economic incentive to exercise renewal options or not to exercise termination options. Lease term modifications from the exercise or non-exercise of such options are only considered in the lease term if they are reasonably certain and are based on an event that is within the control of the lessee.

Financial liabilities

All financial liabilities are initially measured at fair value, in the case of loans and liabilities less directly attributable transaction costs. After initial recognition, financial liabilities measured at amortized cost are measured at amortized cost using the effective interest method.

In the case of financial liabilities, the Group has not yet made use of the option to designate these as financial liabilities at fair value through profit or loss upon initial recognition.

M+M does not use derivative financial instruments.

Inventory

The valuation of the inventory depends on the regulations of IAS 2. This position contains mainly finished goods which are capitalized at cost. If necessary, an inventory valuation adjustment is made due to a reduced usability. All recognizable risks are considered by appropriate adjustments.

Income taxes

Income taxes include current income taxes payable as well as deferred taxes. Tax liabilities mainly comprise liabilities for domestic and foreign income taxes. They include liabilities for the current period as well as for prior periods. The liabilities are measured based on the applicable tax law in the countries where M+M operates and include all facts of which the Company is aware.

Deferred tax assets and liabilities are recognized for temporary differences between the carrying amounts in the consolidated balance sheet and the tax base, as well as for tax loss carry forwards. Deferred tax assets are recognized to the extent that it is probable that future taxable profit will be available against which the temporary differences can be utilized. Deferred tax is not recognized if it arises from the initial recognition of an asset or liability in a transaction other than a business combination that at the time of the transaction affects neither accounting nor taxable profit or loss.

Deferred tax liabilities are recognized on planned dividend payments by subsidiaries. Where a dividend payment is not planned for the long term, no deferred tax liability is recognized on the difference between the proportionate net assets according to IFRS and the tax base of the investment in the subsidiary.

Currently enacted tax laws and tax laws that have been substantively enacted as of the balance sheet date are used as the basis for measuring deferred taxes.

Borrowing costs

In accordance with IAS 23, borrowing costs are charged to expenditure.

If the construction phase of property, plant or equipment extends over a long period, the interest incurred on borrowed capital up to the date of completion is capitalized as part of the cost of acquisition or construction (Borrowing Costs).

Government grants

Government grants compensating expenses are recognized in profit or loss as other operating income in the period in which the related expenses incurred.

Equity costs

According to IAS 32 the costs for the capital increase are offset with the additional paid in capital.

Accruals

Pursuant to IAS 37, accruals are to be reported at the amount resulting from the best estimate of the financial outflow required to meet current obligations as at the balance sheet date.

The value stated for other accruals takes into account all identifiable risks based on past experience and where the scope and maturity is uncertain.

Pension accruals

The pension accruals mainly exist at the parent company and refer to a defined benefit plan for the Managing Directors. The pension commitment contains a retirement pay, a widow's pension as well as a disablement pension. In the case of pension, the payments are made monthly in advance. Pursuant to the Projected Unit Credit Method according to IAS 19 the pension accruals are measured at the present value of the defined benefit liability and cover all benefits after termination of employment.

The calculations were based on the following assumptions:

	2025	2024
Discount rates	3.90%	3.40%
Estimated return on plan assets	2.00%	2.00%
Future changes in Remunerations	1.64%	1.64%

The amount of the pension obligations was determined using actuarial principles using biometric data. The provision is reduced by the amount of the plan assets which consist of pension liability insurances. The service cost is disclosed in staff costs and other comprehensive income.

The actuarial gains and losses arising from two defined benefit plans are recognized in other comprehensive income.

Other assets and liabilities

For all identifiable risks of other assets, appropriate allowances are taken.

Liabilities are valued at their repayment value.

Foreign currency assets and liabilities

In the individual financial statements, assets and liabilities are translated at the rate on the balance sheet date. Profits and losses from the translation of foreign currency receivables and liabilities are reported in the Statement of Income under the financial result. As the income and expenses are not substantial, there are no notes relating to this position.

Principles of revenue recognition

Revenue from the sale of products (software) and other related services is recognised when the customer obtains control of them.

M+M recognises revenues from services, especially maintenance contracts, over a specific period of time, since the customer receives the benefit from the Group's services and simultaneously utilises this benefit.

Revenue from the sale of software is recognised at a specific point in time, generally upon delivery.

M+M usually issues invoices with payment terms of less than 60 days.

For sales transactions with several partial services, such as the sale of products and related services or maintenance agreements, sales are allocated to the various services mainly on the basis of their estimated relative individual sales prices.

The Group pays its employees sales commissions for each contract they win for the bundled sale of software and services. These additional costs of initiating a contract are recognised immediately as an expense when they are incurred if the amortisation period would not exceed one year.

Deferred revenue

If a customer pays a consideration before the Group transfers goods or services to it, a deferred revenue item is recognised when the payment is made or becomes due. Deferred revenues are recognised as revenue as soon as the Group meets its contractual obligations.

Related parties

M+M's Main Shareholder, Chairman of the Board and Managing Director Adi Drotleff and members of his family granted M+M loans amounting to KEUR 2,452 (PY: 2,439) as of Dec 31, 2025 and therefore received interest in 2025 of KEUR 44 (PY: 50).

Notes on the statement of income

1. Revenues

Group sales are generated exclusively from contracts with customers within the meaning of IFRS 15.

Revenues from contracts with customers in the reporting period consisted of service obligations fulfilled at a specific point in time of KEUR 185,164 (PY: 275,198) and service obligations fulfilled over a specific period of KEUR 53,423 (PY: 50,646).

Revenues of KEUR 6,184 (PY: 5,028) were recorded, which were included in deferred revenues in the previous period.

2. Cost of materials

Amounts in KEUR	2025	2024
Cost of materials	-40,739	-137,406
Cost of outstanding services	-2,848	-2,308
Licences in other production cost for proprietary Software	-13,123	-11,540
	-56,710	-151,254

3. Personnel expenses

Amounts in KEUR	2025	2024
Wages and salaries	-91,214	-86,459
Social security	-18,082	-17,020
Share based payments	-183	-209
Pension costs and welfare	-303	-360
Training cost	-581	-762
	-110,363	-104,810

4. Other operating expenses

Amounts in KEUR	2025	2024
Insurance	-605	-819
Cost of buildings	-1,969	-2,022
Travel cost	-3,726	-3,684
Car expenses	-3,218	-3,160
Advertising and promotion	-2,951	-3,606
Communication	-1,034	-1,198
IT expenses	-3,365	-3,827
Consulting and Lawyer fees	-2,113	-1,910
Other	-2,302	-1,986
	-21,283	-22,212

The item 'Other' consist of various items less than KEUR 300.

5. Depreciation and Amortization

Amounts in KEUR	2025	2024
Depreciation of property, plant and equipment	-2,240	-2,332
Depreciation of other intangible assets	-1,969	-1,631
Amortization due to purchase price allocated intangible assets (PPA)	-517	-517
Depreciation finance lease	-6,585	-5,783
	-11,311	-10,263

6. Other operating income

Amounts in KEUR	2025	2024
Return from private use of cars and telephone	1,797	1,756
Rents received	273	254
Marketing funds	1,088	1,274
Development grants	1,026	708
Capitalized own contributions for internal IT projects	1,200	1,100
Capitalized own contributions for software product development	3,000	3,100
Other	1,802	978
	10,186	9,170

The item 'Other' consist of various items less than KEUR 300.

7. Financial result

Amounts in KEUR	2025	2024
Interest income	296	466
Interest expenses	-594	-322
Income from investments and participations	0	9
Minority interest in VAR business partners	0	-158
Other income and expenses	-482	-434
Interest for finance lease IFRS16	-191	-170
Foreign currency exchange gains / losses	-1,073	-333
Financial result	-2,044	-942

8. Taxes on income

This item encompasses actual tax expenses amounting to KEUR 11,960 (PY: 10,469), a relief amounting to KEUR 88 (PY: 245) from further development and revaluation of deferred tax assets, as well as a charge of KEUR 288 (PY: 1,874) from deferred tax liabilities.

The non permanent differences include deferred tax assets amounting to KEUR 1,363 (PY: 1,314) primarily from different valuations of accruals. Furthermore, the temporary differences resulted in deferred tax liabilities of

KEUR 7,584 (PY: 7,299), primarily from the capitalization of development costs.

The average domestic tax rate contains the corporate income tax ("Körperschaftsteuer") plus solidarity surcharge ("Solidaritätszuschlag") as well as the trade tax ("Gewerbesteuer") and has decreased to 29% due to the gradual reduction of the corporate income tax rate.

The transition between the expected taxes and the actual tax proceeds are explained by the reconciliation in the following table:

❖ Tax reconciliation		
Amounts in KEUR	2025	2024
Result before income tax	47,062	45,533
Average domestic tax rate	29%	30%
Expected tax charge	-13,648	-13,660
Tax rate deviation	474	0
Domestic and foreign tax rate differential	928	1,435
Deviation of the taxable base from		
Non-period income taxes	105	226
Non deductible expenses	-317	-331
Tax free income from investments	0	0
Tax-free grants	298	248
Valuation of deferred tax assets		
Non-recognition of deferred tax assets	0	-16
Actual tax charge	-12,160	-12,098
Effective tax rate in percent	25.84%	26.57%

9. Calculation of shares outstanding and earnings per share

In accordance with IAS 33, a weighted average was calculated for shares outstanding. The diluted number of shares does not only include the original subscribed capital shares, but also all option rights from the employee option program which were exercisable at the statement closing date, but which had not yet been exercised.

The number of shares in treasury stock are included in the calculation of earnings per share.

	2025	2024
Net result in KEUR	31,811	30,487
Weighted number of shares	16,662,995	16,907,847
Undiluted earnings per share in EUR	1.9091	1.8031

The diluted and undiluted number of shares as well as the net result is identical.

Notes on the balance sheet

Assets

Current assets

10. Trade accounts receivable

Trade accounts receivable comprised in the group's individual companies include reasonable adjustments and generally have a remaining term of less than one year.

Non current receivables relate to commissions from Autodesk multi-year contracts that are not due in the current fiscal year.

The receivables are reduced by allowance amounting to KEUR 938 (PY: 1,027).

With respect to the trade receivables that are neither impaired nor past due, there are no indications as of the reporting date that the debtors will not meet their payment obligations.

The following table shows the development of allowances on trade receivables:

Amounts in KEUR	2025	2024
Allowances as of Jan 1	1,027	1,010
Currency differences	-5	3
Addition	285	290
Disposal	-101	-108
Reversing	-268	-168
Allowances as of Dec 31	938	1,027

In the current and the prior year no material expenses for the full write-off of trade receivables as well as income from recoveries on trade receivables written off occurred.

All income and expenses relating to allowances and write-offs of trade receivables are reported under other operating expenses.

11. Inventories

This position predominantly contains purchased goods amounting to KEUR 7,476 (PY: 8,080), software licenses amounting to KEUR 2 (PY: 0) and work in process amounting to KEUR 341 (PY: 356). As in the previous year allowances have not been made.

12. Other current assets

This position primarily comprises tax credits, loans and creditor receivables from pending reimbursements.

Non current assets

The development of the non current assets is indicated in the fixed assets register on the next two pages.

The column 'Others' includes reclassifications, write-ups as well as consolidation effects.

Trade receivables							
Amounts in KEUR	Book value	of which neither impaired nor past due on the reporting date	of which not impaired on the reporting date and past due in the following periods				
			30 < 60	60 < 90	90 < 180	180 < 360	> 360
As of Dec 31, 2025	47,942	44,048	1,224	643	1,367	429	231
As of Dec 31, 2024	35,171	31,071	1,530	879	1,154	537	0

Fixed assets register 2024

	Acquisition costs						Accumulated depreciation						Net book value	
	Jan 01, 24	Others	Currency	Addition	Disposal	Dec 31, 24	Jan 01, 24	Others	Currency	Addition	Disposal	Dec 31, 24	Jan 01, 24	Dec 31, 24
I. Tangible assets	17,451	-11	19	1,844	-1,958	17,345	11,933	-65	-2	1,926	-1,863	11,929	5,518	5,416
II. Property	22,157	20	20	20	-9	22,208	4,471	0	21	406	-9	4,889	17,686	17,319
III. Other intangible assets	54,391	-194	-6	8,454	-101	62,544	32,381	-123	-8	2,148	-101	34,297	22,010	28,247
1. Development costs	12,668	0	0	3,600	0	16,268	7,399	0	0	661	0	8,060	5,269	8,208
2. Purchase price allocation	22,392	0	0	0	0	22,392	17,708	0	0	517	0	18,225	4,684	4,167
3. Other	19,331	-194	-6	4,854	-101	23,884	7,274	-123	-8	970	-101	8,012	12,057	15,872
IV. Goodwill	54,185	0	0	0	0	54,185	6,311	0	0	0	0	6,311	47,874	47,874
V. Financial assets	36	0	0	1	-5	32	0	0	0	0	0	0	36	32
VI. Right of use leasing contracts	24,830	0	-74	5,753	-4,862	25,647	13,340	0	-33	5,783	-4,861	14,229	11,490	11,418
(all amounts in KEUR)	173,050	-185	-41	16,072	-6,935	181,961	68,436	-188	-22	10,263	-6,834	71,655	104,614	110,306

13. Goodwill

The development of goodwill is shown in the Goodwill register.

All acquired companies within the 'market offensive' in Germany, Austria and Switzerland are summarized under 'VAR Business D/A/CH'.

14. Leasing

M+M has leasing contracts in place for office space, vehicles, operating and business equipment and software. Leasing agreements for vehicles, operating and office equipment and software generally have terms of between 3 and 5 years, while the term for office rent is usually between 2 and 10 years.

The following table shows the leasing liabilities and the changes during the reporting period:

Amounts in KEUR	2025	2024
As of Jan 1	11,561	11,626
Addition	8,699	5,753
Interest	191	170
Payment	-6,564	-5,781
Currency	-254	-207
As of Dec 31	13,633	11,561
thereof short term	6,125	5,162
thereof long term	7,508	6,399

Goodwill development

Amounts in KEUR	Dec 31, 2024	Addition / Impairment	Currency	Dec 31, 2025
VAR Business D/A/CH	16,214			16,214
SOFISTIK	13,196			13,196
OPEN MIND	10,733			10,733
MuM UK	2,982			2,982
MuM Romania	1,610			1,610
DATAflor	1,216			1,216
MuM Italy	1,116			1,116
MuM Poland	474			474
MuM France	333			333
Total	47,874			47,874

Fixed assets register 2025

	Acquisition costs						Accumulated depreciation						Net book value	
	Jan 01, 25	Others	Currency	Addition	Disposal	Dec 31, 25	Jan 01, 25	Others	Currency	Addition	Disposal	Dec 31, 25	Jan 01, 25	Dec 31, 25
I. Tangible assets	17,345	2	-154	2,142	-1,414	17,921	11,929	0	-100	1,830	-1,254	12,405	5,416	5,516
II. Property	22,208	0	-21	15	0	22,202	4,889	0	-20	410	0	5,279	17,319	16,923
III. Other intangible assets	62,544	0	-4	8,081	-188	70,433	34,297	0	-1	2,486	-188	36,594	28,247	33,839
1. Development costs	16,268	0	0	3,500	0	19,768	8,060	0	0	761	0	8,821	8,208	10,947
2. Purchase price allocation	22,392	0	0	0	0	22,392	18,225	0	0	517	0	18,742	4,167	3,650
3. Other	23,884	0	-4	4,581	-188	28,273	8,012	0	-1	1,208	-188	9,031	15,872	19,242
IV. Goodwill	54,185	0	0	0	0	54,185	6,311	0	0	0	0	6,311	47,874	47,874
V. Financial assets	32	0	0	79	-12	99	0	0	1	0	0	1	32	98
VI. Right of use leasing contracts	25,647	0	-96	8,698	-2,746	31,503	14,229	0	-34	6,585	-2,746	18,034	11,418	13,469
(all amounts in KEUR)	181,961	2	-275	19,015	-4,360	196,343	71,655	0	-154	11,311	-4,188	78,624	110,306	117,719

The cash outflows for leases amounted to KEUR 6,564 (PY: 5,781), while non-cash additions of rights of use and lease liabilities amounted to KEUR 8,699 (PY: 5,753).

The maturity analysis of the leasing liabilities is shown under the item "Liquidity risks" on page 60.

The following amounts were recognised in profit or loss in the reporting period:

Amounts in KEUR	2025	2024
Depreciation leasing	6,585	5,783
Interest for finance lease	191	170
Total amount recognized in profit and loss	6,776	5,953

The weighted average marginal borrowing rate used for the recognition of lease liabilities is 1.5%.

Development right of use leasing 2025

Amounts in KEUR	Jan 1, 2025	Addition/Disposal	Depreciation	Currency	Dec 31, 2025
Offices	6,659	3,462	-2,508	-66	7,547
Cars	3,523	2,246	-2,243	3	3,529
Equipment	125	17	-53	0	89
Software	1,111	2,974	-1,781	0	2,304
Total	11,418	8,699	-6,585	-63	13,469

Development right of use leasing 2024

Amounts in KEUR	Jan 1, 2024	Addition/Disposal	Depreciation	Currency	Dec 31, 2024
Offices	6,991	2,302	-2,624	-10	6,659
Cars	3,469	2,160	-2,080	-26	3,523
Equipment	150	36	-61	0	125
Software	874	1,255	-1,018	0	1,111
Total	11,484	5,753	-5,783	-36	11,418

Liabilities

Current liabilities

15. Short term debt and current portion of long term debt

This position almost exclusively contains bank loans at principal banks in Germany and abroad in the context of credit lines. They are partly secured by assignments of receivables.

In the balance sheet, the bank liabilities classified as current are those which have to be paid back within the next 12 months. Fixed credit lines with indefinite durations are classified as non current, even if they are refinanced on a short term base (low interest rates). This increases the clarity of the financing structure, and avoids the wrong impression that most of the bank debt would be short-term.

A liquidity reserve in the form of credit lines and, where necessary, cash is maintained to guarantee the solvency and financial flexibility of M+M at all times. For this purpose, the Company entered into credit agreements with various international and domestic banks amounting to a total of EUR 46.0 million (PY: 34.0). M+M does not pay commitment fees on unused credit lines.

16. Accrued expenses

Accruals are calculated by taking all identifiable risks into account and always represent the expected repayment amount.

The development of the accruals in the reporting period is shown in the table of accrual development.

The other non current accruals mainly include provisions for archiving.

Table of accrual development

Amounts in KEUR	Dec 31, 2024	Disposal	Addition	Dec 31, 2025
Personnel accruals	10,467	-5,207	5,821	11,081
Outstanding bills	1,026	-1,008	1,120	1,138
Other	912	-201	298	1,009
Total current accruals	12,405	-6,416	7,239	13,228
Other accruals	80	0	0	80
Total non current accruals	80	0	0	80
Total accruals	12,485	-6,416	7,239	13,308

17. Other current liabilities

This position includes debts from VAT and tax on wages and salaries, outstanding social security costs and deferred income.

Non current liabilities**18. Long term debt, less current portion**

This position contains the fixed and unsecured credit lines with indefinite period of redemption, shareholder loans as well as bank loans for financing properties secured by mortgages.

19. Long-term trade accounts payable

This item contains liabilities to Autodesk from multi-year contracts that are not due in the current financial year.

Debt				
Amounts in KEUR	Total	within 1 year	due > 1 year < 5 years	due > 5 years
As of Dec 31, 2025				
Debt	33,683	10,231	23,452	0
Real estate financing secured by mortgage	2,099	366	802	931
Financial liability	35,782	10,597	24,254	931
As of Dec 31, 2024				
Debt	5,105	2,647	2,458	0
Real estate financing secured by mortgage	2,466	366	1,068	1,032
Financial liability	7,571	3,013	3,526	1,032

Changes in liabilities arising from financing activities					
Amounts in KEUR	As of	Cash Flow	Currency	Other	As of
	Jan 1, 2025				Dec 31, 2025
Short term debt and current portion of long term debt	3,013	7,594	-10	0	10,597
Long term debt, less current portion	2,459	20,993	0	0	23,452
Real estate financing secured by mortgage	2,099	-366	0	0	1,733
Financial liability	7,571	28,221	-10	0	35,782
	Jan 1, 2024				Dec 31, 2024
Short term debt and current portion of long term debt	2,375	638	0	0	3,013
Long term debt, less current portion	2,732	-273	0	0	2,459
Real estate financing secured by mortgage	2,465	-366	0	0	2,099
Financial liability	7,572	-1	0	0	7,571

20. Pension accrual

The pension accruals essentially exist at the parent company and refer to a defined benefit plan for the Managing Directors. The pension commitment contains a retirement pay, a widow's pension as well as a disability pension.

The pension accruals are determined according to actuarial principles of the projected unit credit method in accordance with IAS 19.

The pension accruals at the balance sheet date amount to KEUR 0 (PY: 85), of which an amount of KEUR 0 (PY: 85) represents the determined cash value of the performance-oriented obligation not financed via funding.

The cash value determined as at the balance sheet date of the performance-oriented obligations financed via funds amounts to KEUR 2,311 (PY: 2,547). This figure also corresponds to the fair value of the plan assets as at the balance sheet date. The Statement of Income includes income from plan assets amounting to KEUR 89 (PY: 89), interest expenses amounting to KEUR 92 (PY: 94) and current time of service expenditure amounting to KEUR 0 (PY: 0).

The stated expenses and income are included in the personnel expenses and the financial result.

The recognition of actuarial gains and losses are shown in total in other comprehensive income (see notes to the pension accruals on page 47).

In the financial year, pension has been paid in the amount of KEUR 334 (PY: 150).

The reconciliation to the net recognized liability is as follows:

Amounts in KEUR	2025	2024
Benefit obligation at start of the year	2,632	2,741
Interest cost	92	94
Benefits paid	-334	-150
Net actuarial gain	-135	-53
Benefit obligation at end of year	2,255	2,632
Plan assets at start of year	2,547	2,593
Received contributions	-334	-150
Actual return on plan assets	89	89
Net actuarial gain	9	15
Plan assets at end of year	2,311	2,547
Settlement over-collateralization	56	0
Net recognized liability	0	85

Pension benefits payable in the future are estimated as follows:

<u>Year</u>	<u>Amounts in KEUR</u>
2026	176
2027	178
2028	181
2029	184
2030	186
2031 - 2035	976

The benefit obligation has an average statistical expected remaining life of 11 years (PY: 12).

The table below shows the sensitivity of pension accruals on changes in the parameters:

<u>Amounts in KEUR</u>	<u>2025</u>	<u>2024</u>
Change in discount rate +0.5%	-81	-104
Change in discount rate -0.5%	88	115
Change in projected future benefit increases +0.5%	17	31
Change in projected future benefit decreases -0.5%	-16	-28
Change in life expectancy + 1 year	56	70

When calculating the sensitivity of the DBO to significant assumptions, the same method has been applied as when calculating the pension liability recognised in the statement of financial position. The above sensitivity analysis are based on a change in one assumption while holding all other assumptions constant.

Shareholders' equity

21. Share capital

The subscribed capital of M+M SE as of Dec 31, 2025, comprised 17,149,052 (PY: 17,149,052) shares, with a calculated stake of EUR 1.00 per share.

As of Dec 31, 2025 the approved capital amounts to KEUR 3,430 (PY: 3,430). It was authorized by the general meeting on May 11, 2023 and expires on May 11, 2028.

22. Capital reserve

The development of the capital reserve is shown by the following table:

<u>Amounts in KEUR</u>	<u>2025</u>	<u>2024</u>
Capital reserve as of Jan 1	49,299	47,160
Share dividend	1,184	2,457
Delivery of own shares	-122	148
Acquisition of additional shares of already fully consolidated companies	-939	-466
Capital reserve as of Dec 31	49,422	49,299

23. Treasury stock

In the year 2025 M+M acquired 657,686 (PY: 171,085) M+M shares at a total amount of KEUR 31,460 (PY: 9,157) or EUR 47.83 (PY: 53.53) per share.

In the financial year, 202,740 (PY: 162,592) treasury shares with a total book value of KEUR 9,819 (PY: 6,837) or EUR 48.43 (PY: 42.05) per share were used to service the stock dividend at a price of EUR 54.27 (PY: 57.17) per share.

The capital gain of KEUR 1,184 (PY: 2,457) was recorded in capital reserves.

For the employee participation program 21,518 (PY: 19,786) treasury shares were used at a total amount of KEUR 1,032 (PY: 1,047) or EUR 47.94 (PY: 52.90) per share.

The amount of the discount granted to employees of KEUR 183 (PY: 209) was recognized as personnel expenses (see page 48).

In 2025 the shares of treasury stock increased on balance by 433,428 (PY: reduced by 45,552) shares and KEUR 20,664 has been spent (PY: 518 realized).

As of Dec 31, 2025, M+M held 683,204 (PY: 249,776) shares of treasury stock. This is 3.98% (PY: 1.46%) of the issued capital.

Treasury shares are carried at cost amounting to KEUR 32,336 (PY: 11,726) or EUR 47.33 (PY: 46.94) per share. According to IFRS they are treated in the balance sheet like retired shares and must be deducted from equity.

Notes on the cash flow statement

The cash flow statement classifies cash flows according to operating, investing and financing activities. Cash and cash equivalents in the cash flow statement correspond to total cash and cash equivalents on the balance sheet.

This position contains cash in form of liquid funds and sight deposit accounts as well as cash equivalents consisting of fixed term deposits and money market papers, which can be transferred into cash at any time and therefore are suspended from substantial interest or currency risks.

Flows of funds from the acquisition and sale of consolidated companies are included in cash flows from investing activities. Effects of foreign exchange rate changes are stated separately.

Among other items, cash flows from operating activities include:

- KEUR 15,337 (PY: 10,651) paid for taxes on income (net of income tax refunds)
- cash flows from investments (dividends) amounting to KEUR 0 (PY: 9)

The other non cash expenses / income are mainly the change of the deferred taxes amounting to KEUR 200 (PY: 1,609), the change of deferred revenues of KEUR 639 (PY: 1,156) and the change of the other comprehensive income of KEUR 49 (PY: 147).

In the cash flows from financing activities dividends to M+M shareholders amounting to KEUR 30,672 (PY: 27,771) or EUR 1.85 (PY: 1.65) per share are included of which KEUR 11,003 (PY: 9,293) was contributed back to equity since the option share dividend was chosen. The actual total payment to M+M shareholders was KEUR 19,669 (PY: 18,478).

There are no restrictions on the disposal of cash and cash equivalents.

Other supplementary information**Other financial obligations and contingent liabilities**

Until Dec 31, 2018 the other financial obligations were mainly the result of long term rental and operating lease contracts for the group as a whole.

Since January 1, 2019 these are recognised in the balance sheet as rights of use according to IFRS 16. There were no further relevant other financial obligations as of Dec 31, 2025.



Risk management

Principles of risk management

M+M is exposed in particular to risks from movements in exchange and interest rates, as well as liquidity, other price and credit risks that affect its assets, liabilities, and forecast transactions.

Financial risk management aims to limit these risks through ongoing operational and finance activities.

Currency risk

M+M is exposed to currency risks from its investing and operating activities. Usually foreign currencies are not hedged. The individual Group entities predominantly execute their operating activities in their respective functional currencies. This is why the assessment of exchange rate risk from ongoing operations is low.

The following table demonstrates the sensitivity to a reasonable possible change in the EURO exchange rate to all other currencies, with all other variables held constant, of the Group's profit before tax (due to changes in the fair value of monetary assets and liabilities).

Amounts in KEUR	2025	2024
Increase of 5%	-229	-650
Decrease of 5%	229	650

Interest risk

Interest rate risks are presented by way of sensitivity analyses in accordance with IFRS 7. These show the effects of changes in market interest rates on interest payments, interest income and expense.

Changes in the market interest rates of non-derivative financial instruments with fixed interest rates only affect income if these are measured at their fair value. As such, all financial instruments with fixed interest rates that are carried at amortized cost are not subject to interest rate risk as defined in IFRS 7.

The following table demonstrates the sensitivity to a reasonable possible change in interest rates, with all other variables held constant, of the Group's profit before tax and shareholders equity (through the impact on floating rate borrowings).

Amounts in KEUR	2025	2024
Increase of 25 basis points	-40	-9
Decrease of 25 basis points	40	9

Liquidity risks

The following tables show contractually agreed (undiscounted) interest payments and maximum possible repayments of the non-derivative financial liabilities:

The variable interest payments arising from the financial instruments were calculated using the last interest rates fixed before the balance sheet date. Financial liabilities that can be repaid at any time are always assigned to the earliest possible time period.

❖ Liquidity risk 2025

Amounts in KEUR	Book value	Cash flows 2026		Cash flows 2027		Cash flows from 2028	
	Dec 31, 2025	Interest rate	Repayment	Interest rate	Repayment	Interest rate	Repayment
Bank debt	33,330	22	31,597	17	368	76	1,365
Shareholders' loan	2,452		2,452				
Trade accounts payable	27,063	0	26,783	0	280		
Other current liabilities	2,645		2,645				
Finance lease obligation	13,633	0	6,125	0	3,413	0	4,095

❖ Liquidity risk 2024

Amounts in KEUR	Book value	Cash flows 2025		Cash flows 2026		Cash flows from 2027	
	Dec 31, 2024	Interest rate	Repayment	Interest rate	Repayment	Interest rate	Repayment
Bank debt	5,312	27	3,012	22	387	93	1,733
Shareholders' loan	2,439		2,439				
Trade accounts payable	49,707		33,414		16,293		
Other current liabilities	3,482		3,482				
Finance lease obligation	11,561		5,162		2,909		3,490

All instruments held at balance sheet date were included. Planning data for future, new liabilities is not included. Amounts in foreign currency were each translated at the closing rate at the reporting date.

The expected future outflow of cash is covered by the operating business, the trade accounts receivables as well as the available credit lines.

The following table shows the carrying amounts and fair values of financial assets and liabilities by category of financial instrument and reconciliation to the corresponding line item in the balance sheet.

Since the line items 'Other receivables' and 'Other liabilities' contain both financial instruments and non-financial assets and liabilities (such as other tax receivables or advance payments for services to be received in the future), the reconciliation is shown in the column headed 'Non-financial assets / liabilities'.

As a matter of principle the fair value is determined on the hierarchic level 2 with consideration of prices not noted or indirectly derived from prices noted on active markets.

❖ Fair Values 2025						
Amounts in KEUR						
	Category in accordance with IFRS 9	Book value Dec 31, 2025	Fair Value Dec 31, 2025	Amounts recognized in balance sheet according to IFRS9 Amortized cost	non-financial assets / liabilities	Book value balance sheet Dec 31, 2025
Assets						
Cash and cash equivalents	AC	15,760	15,760	15,760		15,760
Trade accounts receivable	AC	47,942	47,942	47,942		47,942
Other current assets	AC	3,783	3,783	3,783	6,779	10,562
Liabilities						
Bank debt	AC	33,330	33,165	33,330		33,330
Shareholders' loan	AC	2,452	2,452	2,452		2,452
Trade accounts payable	AC	27,063	27,063	27,063		27,063
Other liabilities	AC	2,645	2,645	2,645	4,345	6,990
Of which aggregated by category in accordance with IFRS 9						
Financial assets measured at fair value through profit or loss	AC	67,485	67,485	67,485		
Financial Liabilities Measured at Amortised Cost (FLAC)	AC	65,490	65,325	65,490		

❖ Fair Values 2024						
Amounts in KEUR						
	Category in accordance with IFRS 9	Book value Dec 31, 2024	Fair Value Dec 31, 2024	Amounts recognized in balance sheet according to IFRS9 Amortized cost	non-financial assets / liabilities	Book value balance sheet Dec 31, 2024
Assets						
Cash and cash equivalents	AC	42,997	42,997	42,997		42,997
Trade accounts receivable	AC	35,171	35,171	35,171		35,171
Other current assets	AC	3,311	3,311	3,311	10,357	13,668
Liabilities						
Bank debt	AC	5,132	4,982	5,132		5,132
Shareholders' loan	AC	2,439	2,439	2,439		2,439
Trade accounts payable	AC	49,707	49,707	49,707		49,707
Other liabilities	AC	3,482	3,482	3,482	3,666	7,148
Of which aggregated by category in accordance with IFRS 9						
Financial assets measured at fair value through profit or loss	AC	81,479	81,479	81,479		
Financial Liabilities Measured at Amortised Cost (FLAC)	AC	60,760	60,610	60,760		

Cash and cash equivalents, and trade and other receivables mainly have short times to maturity. For this reason, their carrying amounts at the reporting date approximate the fair values.

Trade and other payables, as well as other liabilities, generally have short times to maturity; the values reported approximate to the fair values.

The fair values of unquoted bonds, liabilities to banks, promissory notes, and other financial liabilities are calculated as the present values of the payments associated with the debts, based on the applicable yield curve.

Other price risks

As part of the presentation of market risks, IFRS 7 also requires disclosures on how hypothetical changes in risk variables affect the price of financial instruments. Important risk variables are stock exchange prices or indexes.

As of December 31, 2025, M+M did not hold any material investments to be classified as 'available-for-sale'.

Credit risk

M+M trades only with recognized, credit-worthy third parties. It is the Group's policy that all customers who wish to trade on credit terms are subject to credit verification procedures. In addition, receivable balances are monitored on an ongoing basis with the result that the exposure to bad debts is not significant. The maximum exposure is the carrying amount.

There are no significant concentrations of credit risk. With respect to credit risk arising from the other financial assets, which comprise cash and cash equivalents, available-for-sale financial investments, loan notes and certain derivative instruments, the exposure to credit risk arises from default of the counterparty, with a maximum exposure equal to the carrying amount of these instruments.

Credit risks are handled with specific and lump-sum allowances as well as a credit sale insurance. The credit sale insurance covers 70% to 90% of the insured receivable in the case of loss of receivables outstanding. Because of the structure of our customers there are no significant concentrations of credit risk.



Capital management

The primary objective of the capital management of M+M was to ensure that it maintains a strong credit rating and healthy capital ratio in order to support its business and maximize shareholder value. M+M's policy is to keep an equity ratio of at least 30%.

Above that the gearing ratio should be below 3 times EBITDA.

The gearing ratio of 0.37 (PY: -0.70) and the equity ratio of 42.13% (PY: 49.51%) are within the objectives.

To maintain or adjust the capital structure, the Group may adjust the dividend payment to shareholders or issue new shares. No changes were made to the objectives, policies and methods as of December 31, 2025.

Research and development expenses

The research and development expenses for the financial year amounted to KEUR 28,965 (PY: 26,713).

Thereof EUR 3,500 (PY: 3,600) was capitalized as development cost for individual projects under other intangible assets, because their future recoverability could reasonably be assured.

Employees

The group's average number of employees (full time equivalent) during the fiscal year was 1,127 (PY: 1,095).

Administrative Board

The Administrative Board consists of the following persons:

Adi Drotleff, Diplom-Informatiker, Munich (Chairman)

Heike Lies, Magister Artium, Munich, Municipal employee (Deputy Chairwoman)

Dr. Rupprecht von Bechtolsheim, Independent attorney, Munich

According to article 23 and 24 of the SE implementing law in connection with article 10, para 1, of the articles of association of Mensch und Maschine Software SE, the Administrative Board is made up of three members and is elected for 5 years. The last election was on May 11, 2021.

Managing Directors

The following gentlemen were Managing Directors during fiscal year 2025:

Adi Drotleff, Diplom-Informatiker, Munich (Strategy/Communication)

Markus Pech, Betriebswirt (FH), Schrobenhausen (CFO)

The company is legally represented by two Managing Directors or by one Managing Director together with a person authorized to sign. Mr. Adi Drotleff has sole representation authorization.

Remuneration of Managing Directors and Administrative Board

The remuneration for the Managing Directors in 2025 amounted to KEUR 833 (PY: 783). It was composed of fixed salaries of KEUR 332 (PY: 321), variable components of KEUR 456 (PY: 416) and non-cash salary components of KEUR 45 (PY: 46).

The pension obligation for the Managing Directors amounted to KEUR 1,481 (PY: 1,626) as of December 31, 2025.

Remuneration for the Administrative Board in 2025 totaled KEUR 24 (PY: 24).

Audit fees

The required disclosure of the group auditor's fee volume is as follows:

Amounts in KEUR	2025	2024
Audit	251	246
Tax consulting	113	112
Total	364	358

**Appropriation of retained earnings of
Mensch und Maschine Software SE**

Mensch und Maschine Software SE has unappropriated retained earnings amounting to KEUR 35,474 as of December 31, 2025.

The administrative board will propose to the shareholders meeting a dividend of EURO 2.00 per share for fiscal year 2025. With consideration of the 834,595 shares in treasury stock acquired till February 27, 2026, the total dividend payment amounts to KEUR 32,628. The remaining balance of KEUR 2,845 is carried forward.

If the number of shares in treasury stock should change before the shareholders' meeting on May 12, 2026, the dividend payment will be adapted accordingly.

“INDEPENDENT AUDITOR’S REPORT**to the Mensch und Maschine Software SE:****Audit Opinions**

We have audited the consolidated financial statements of Mensch und Maschine Software SE and its subsidiaries (the Group) - consisting of consolidated balance sheet as at December 31, 2025, the consolidated profit and loss statement and the consolidated statement of comprehensive income, the consolidated statement of changes in equity, the consolidated cash flow statement for the financial year from January 1 to December 31, 2025, and the notes to the consolidated financial statements, including material accounting policy informations. In addition, we have audited the group management report of Mensch und Maschine Software SE for the financial year from January 1 to December 31, 2025.

In accordance with the German legal requirements, we have not audited the following content of the group management report:

- the presentation of the non-financial performance indicators contained in the group management report on pages 16 and 17
- all examples of the software products used presented in the group management report

In our opinion, on the basis of the knowledge obtained in the audit:

- the accompanying consolidated financial statements comply, in all material respects, with the IFRS Accounting Standards issued by the International Accounting Standards Board (IASB) (hereafter “IFRS Accounting Standards”), as adopted by the EU, and the additional requirements of German commercial law pursuant to Article 315e HGB (Handelsgesetzbuch: German Commercial Code) and give a true and fair view of the assets, liabilities and financial position of the Group as at December 31, 2025 and of its financial performance for the financial year from January 1 to December 31, 2025 and
- the accompanying group management report as a whole provides an appropriate view of the Group’s position. In all material respects, this group management report is consistent with the consolidated financial statements, complies with German legal requirements and appropriately presents the opportunities and risks of future development. Our audit opinion on the group management report does not cover the content of the above-mentioned unaudited parts of the group management report.

Pursuant to Article 322 Paragraph 3 Clause 1 HGB, we declare that our audit has not led to any reservations relating to the legal compliance of the consolidated financial statements and of the group management report.

Basis for the Audit Opinions

We conducted our audit of the consolidated financial statements and of the group management report in accordance with Article 317 HGB and in compliance with German Generally Accepted Standards for Financial Statement Audits promulgated by the Institut der Wirtschaftsprüfer [Institute of Public Auditors in Germany] (IDW).

Our responsibilities under those requirements and principles are further described in the “Auditor’s Responsibilities for the Audit of the Consolidated Financial Statements and of the Group Management Report” section of our auditor’s report.

We are independent of the Group Companies in accordance with the requirements of German commercial and professional law, and we have fulfilled our other German professional responsibilities in accordance with these requirements. We believe that the audit evidence we have obtained is sufficient and appropriate to provide a basis for our audit opinions on the consolidated financial statements and on the group management report.

Other Information

The legal representatives and/or the administrative board are responsible for the other information. Other information comprises:

- the above-mentioned unaudited content of the group management report
- all other parts of the annual report, but not the consolidated financial statements, not the audited content of the group management report, and not our Independent Auditor's Report.

The administrative board is responsible for the report of the administrative board. Otherwise, the executive directors are responsible for the other information.

Our audit opinions on the consolidated financial statements and group management report do not cover the other information and consequently we do not express an audit opinion or any other form of assurance conclusion on this subject.

In connection with our audit, our responsibility is to read the other information and, in doing so, to consider whether the other information

- is materially inconsistent with the consolidated financial statements, with the audited content of the disclosures in the management report or our knowledge obtained in the audit, or
- otherwise appears to be substantially misstated.

If, based on the work we have performed, we conclude that there is a material misstatement of this information, we are required to report on that fact. We have nothing to report in this regard.

Responsibilities of the Legal Representatives and the Administrative Board for the Consolidated Financial Statements and the Group Management Report

The executive directors are responsible for the preparation of the consolidated financial statements that comply, in all material respects, with the requirements of IFRS Accounting Standards as adopted by the EU and the additional requirements of German commercial law pursuant to Article 315e Paragraph 1 HGB, and that the consolidated financial statements give a true and fair view of the assets, liabilities, financial position and financial performance of the Group in compliance with these accounting principles. In addition, the legal representatives are responsible for such internal control as they have determined necessary to enable the preparation of consolidated financial statements that are free from material misstatement, whether due to fraud (i.e., fraudulent financial reporting and misappropriation of assets) or error.

In preparing the consolidated financial statements, the legal representatives are responsible for assessing the Group's ability to continue as a going concern. They also have the responsibility for disclosing, as applicable, matters related to going concern. In addition, they are responsible for using the going concern basis of accounting, unless the intention is to liquidate the Group or to cease operations, or there is no realistic alternative but to do so.

Furthermore, the legal representatives are responsible for the preparation of the group management report that as a whole provides an appropriate view of the Group's position and is, in all material respects, consistent with the consolidated financial statements, complies with German legal requirements, and appropriately presents the opportunities and risks of future development. In addition, the executive directors are responsible for such arrangements and measures (systems) as they have considered necessary to enable the preparation of a group management report that is in accordance with the applicable German legal requirements, and to be able to provide sufficient appropriate evidence for the assertions in the group management report.

The administrative board is responsible for overseeing the Company's financial reporting process for the preparation of the consolidated financial statements and of the group management report.

Auditor's Responsibilities for the Audit of the Consolidated Financial Statements and of the Group Management Report

Our objectives are to obtain reasonable assurance about whether the consolidated financial statements as a whole are free from material misstatement, whether due to fraud or error, and whether the group management report as a whole provides an appropriate view of the Group's position and, in all material respects, is consistent with the consolidated financial statements and the knowledge obtained in the audit, complies with the German legal requirements and appropriately presents the opportunities and risks of future development, as well as to issue an auditor's report that includes our audit opinions on the consolidated financial statements and on the group management report.

Reasonable assurance is a high level of assurance but is not a guarantee that an audit conducted in accordance with Article 317 HGB and in compliance with German Generally Accepted Standards for Financial Statement Audits promulgated by the Institut der Wirtschaftsprüfer (IDW) will always detect a material misstatement. Misstatements can arise from fraud or error and are considered material if, individually or in the aggregate, they could reasonably be expected to influence the economic decisions of users taken on the basis of these consolidated financial statements and this group management report.

We exercise professional judgment and maintain professional scepticism throughout the audit. We also:

- Identify and assess the risks of material misstatement of the consolidated financial statements and of the group management report, whether due to fraud or error, design and perform audit procedures responsive to those risks, and obtain audit evidence that is sufficient and appropriate to provide a basis for our audit opinions. The risk of not detecting a material misstatement resulting from fraud is higher than the risk of not detecting a material misstatement resulting from error, as fraud may involve collusion, forgery, intentional omissions, misrepresentations, or the override of internal controls.
- Obtain an understanding of internal control relevant to the audit of the consolidated financial statements and of arrangements and measures (systems) relevant to the audit of the group management report in order to design audit procedures that are appropriate in the circumstances, but not for the purpose of expressing an audit opinion on the effectiveness of internal control or these arrangements and measures.

- Evaluate the appropriateness of accounting policies used by the executive directors and the reasonableness of estimates made by the executive directors and related disclosures.
- Conclude on the appropriateness of the executive directors' use of the going concern basis of accounting and, based on the audit evidence obtained, whether a material uncertainty exists related to events or conditions that may cast significant doubt on the Group's ability to continue as a going concern. If we conclude that a material uncertainty exists, we are required to draw attention in the auditor's report to the related disclosures in the consolidated financial statements and in the group management report or, if such disclosures are inadequate, to modify our respective audit opinions. Our conclusions are based on the audit evidence obtained up to the date of our auditor's report. However, future events or conditions may cause the Group to cease to be able to continue as a going concern.
- Evaluate the overall presentation, structure and content of the consolidated financial statements, including the disclosures, and whether the consolidated financial statements present the underlying transactions and events in a manner that the consolidated financial statements give a true and fair view of the assets, liabilities, financial position and financial performance of the Group in compliance with IFRS Accounting Standards as adopted by the EU and the additional requirements of German commercial law pursuant to Article 315e Paragraph 1 HGB.
- plan and perform the audit of the consolidated financial statements in order to obtain sufficient appropriate audit evidence regarding the financial information of the entities or of the business activities within the Group, which serves as a basis for forming audit opinions on the consolidated financial statements and on the combined management report. We are responsible for the direction, supervision and performance of the audit of the group audit. We are solely responsible for our audit opinions.

- Evaluate the consistency of the group management report with the consolidated financial statements, its conformity with German law, and the view of the Group's position it provides.
- Perform audit procedures on the prospective information presented by the executive directors in the group management report. On the basis of sufficient appropriate audit evidence, we evaluate, in particular, the significant assumptions used by the executive directors as a basis for the prospective information, and evaluate the proper derivation of the prospective information from these assumptions. We do not express a separate audit opinion on the prospective information and on the assumptions used as a basis. There is a substantial unavoidable risk that future events will differ materially from the prospective information.

We communicate with those charged with governance regarding, among other matters, the planned scope and timing of the audit and significant audit findings, including any significant deficiencies in internal control that we identify during our audit.“

Stuttgart, March 10, 2026

dhpg GmbH
Wirtschaftsprüfungsgesellschaft

Elenkamp
Wirtschaftsprüfer

Riedhammer
Wirtschaftsprüfer

Report from the Administrative Board of Mensch und Maschine Software SE, Wessling, according to section 47 para 3, SE implementing law (SE-IL) in conjunction with section 171 para 2, AktG (German Companies act)

The Administrative Board (Verwaltungsrat) will report to the shareholders' meeting according to section 47 para 3, SE implementing law (SE-IL) in conjunction with section 171 para 2, AktG (German Companies act) as follows:

The Administrative Board fulfilled all its obligations as incumbent, pursuant to the corresponding statutes and by-laws, and including the ongoing advice and supervision of the company's Managing Directors. The Administrative Board was involved in all decisions of principal importance for the company. The strategic direction of the M+M group was closely aligned between the Managing Directors and the Administrative Board.

The Managing Directors informed the Administrative Board, orally or in writing, in a regular, timely and extensive manner about all essential matters concerning the short term planning, the actual course of business as well as the financial and earnings situation.

Based on detailed management reports, all business cases significant and essential for the M+M group have been discussed in depth, also concerning the development of the individual subsidiaries. Discrepancies in the course of business from the plan have been discussed intensively.

During fiscal year 2025 four Administrative Board meetings took place on March 10, May 8, October 20 and December 15, 2025.

In particular, the following matters were discussed between the Administrative Board and the Managing Directors:

- Development and maintenance of the group's own software technology
- Transition to Autodesk Agency model
- Investments in internal IT and Software
- Development of Group and individual subsidiaries' operating profitability
- Handover from founder Adi Drotleff to the Group Management Board
- Dividend policy

The Administrative Board received reports about the development of the risk management system; existing risks and their provision were explained by the Managing Directors.

The Administrative Board was also informed in detail about events of material importance in between the regular meetings.

Due to the size of the Board, there were no additional committees. An efficiency test for the activities of the Administrative Board was not explicitly conducted, because improvement processes are constantly discussed and translated into action.

The annual report of Mensch und Maschine Software SE as of December 31, 2025, as well as the group annual report as of December 31, 2025, including the management report for the group was set up by the Managing Directors and audited by dhpG GmbH Wirtschaftsprüfungsgesellschaft, Stuttgart, and endorsed with an unqualified audit opinion.

The Managing Directors' set up and the auditing reports from the auditing firm were available to all members of the Administrative Board.

The auditor took part in the annual fiscal year report meeting on March 12, 2026, and reported upon all significant results of the audit.

The Administrative Board reviewed the annual report and group annual report, the management and group management report and the Managing Directors' suggestion for the use of the net income for the year, and agreed to the annual report and group annual report, raising no objections after its own review.

The Administrative Board has approved the annual report and group annual report, and agreed the Managing Directors' suggestion for the use of the net income for the year.

The Administrative Board would like to thank all employees for their engagement in fiscal year 2025.

Wessling, March 2026
The Administrative Board

Adi Drotleff
Chairman

❖ Addresses					
Company	Street	Town	Telephone	Telefax	Internet
Mensch und Maschine Software SE	Argelsrieder Feld 5	D-82234 Wessling	+49 (0) 81 53 / 9 33 - 0	+49 (0) 81 53 / 9 33 - 100	www.mum.de
Mensch und Maschine Deutschland GmbH	Argelsrieder Feld 5	D-82234 Wessling	+49 (0) 81 53 / 9 33 - 0	+49 (0) 81 53 / 9 33 - 100	www.mum.de
	Friesenweg 20	D-22763 Hamburg	+49 (0) 40 / 89 80 78 - 0		
	Rotenburger Straße 20	D-30659 Hannover	+49 (0) 5 11 / 22 06 17 - 76		
	Martin-Schmeißer-Weg 10	D-44227 Dortmund	+49 (0) 231 / 9 97 63 57 - 0		
	Zum Scherbusch 5	D-51674 Wiehl	+49 (0) 22 97 / 91 14 - 0		
	Neue Jülicher Straße 60	D-52353 Düren	+49 (0) 24 21 / 3 88 90 - 0		
	Am Hohenwiesenweg 1	D-63679 Schotten	+49 (0) 60 44 / 98 91 98		
	Wandersmannstraße 68	D-65205 Wiesbaden	+49 (0) 6 11 / 97 49 18 - 0		
	In den Fritzenstücker 2	D-65549 Limburg	+49 (0) 64 31 / 92 93 - 0		
	Werner-von-Siemens-Allee 4	D-66115 Saarbrücken	+49 (0) 6 81 / 97 05 96 - 0		
	Carl-Mayer-Straße 1	D-73230 Kirchheim/Teck	+49 (0) 70 21 / 9 34 88 - 20		
	Im Kleinfeld 12a	D-79189 Bad Krozingen	+49 (0) 7 61 / 40 13 61 - 0		
	Gabelweg 6	D-88046 Friedrichshafen	+49 (0) 75 41 / 38 14 - 0		
	Flataustraße 14	D-90411 Nürnberg	+49 (0) 911 39 901 - 0		
Mensch und Maschine Infrastruktur GmbH	Andreas-von-Renner Platz 2	D-71254 Ditzingen	+49 (0) 71 56 / 1 76 74 - 0		www.mum.de
Mensch und Maschine acadGraph GmbH	Fritz-Hommel-Weg 4	D-80805 München	+49 (0) 89 / 3 06 58 96 - 0		www.acadgraph.de
	Kohlgartenstraße 15	D-04315 Leipzig	+49 (0) 3 41 / 30 85 47 - 0		
	Morgensternstraße 23	D-12207 Berlin	+49 (0) 30 / 8 91 10 08		
	Oststraße 88	D-22844 Norderstedt	+49 (0) 40 / 43 25 79 - 0		
	Otto-Brenner-Straße 196	D-33604 Bielefeld	+49 (0) 5 21 / 2 81 - 63		
	Poststraße 10	D-34587 Felsberg	+49 (0) 55 62 / 93 14 41 44		
	Neuer Zollhof 3	D-40221 Düsseldorf	+49 (0) 2 11 / 1 57 91 77		
	Stockumer Straße 475	D-44227 Dortmund	+49 (0) 2 31 / 56 03 10 - 40		
	Dülmener Weg 221	D-46325 Borken	+49 (0) 28 61 / 6 80 21 - 0		
	Goetheplatz 5	D-99423 Weimar	+49 (0) 36 41 / 6 35 52 - 5		
Mensch und Maschine At Work GmbH	Gewerbepark 18	D-49143 Bissendorf	+49 (0) 5 41 / 4 04 11 - 0		www.work-os.de
customX GmbH	Auf den Sechsmorgen 25	D-65589 Hadamar	+49 (0) 64 33 / 94 761 - 0		www.customx.de
Mensch und Maschine Scholle GmbH	Rheinlandstraße 24	D-42549 Velbert	+49 (0) 20 51 / 8087900		www.scholle.de
Mensch und Maschine Austria GmbH	Argentinierstraße 64/5	A-1040 Wien	+43 (0) 1 / 5 04 77 07 - 0	+43 (0) 1 / 5 04 77 07 - 27	www.mum.at
	SOHO 2 - Grabenweg 68	A-6020 Innsbruck	+43 (0) 52 23 / 4 20 08	+43 (0) 33 85 / 6 60 01 33	
	Hartert Straße 1	A-8053 Graz	+43 (0) 3 16 / 93 12 55	+43 (0) 33 85 / 6 60 01 33	
	Großwilfersdorf 102/1	A-8263 Großwilfersdorf	+43 (0) 33 85 / 6 60 01	+43 (0) 33 85 / 6 60 01 33	
Mensch und Maschine Schweiz AG	Zürichstrasse 25	CH-8185 Winkel	+41 (0) 44 / 8 64 19 00	+41 (0) 44 / 8 64 19 01	www.mum.ch
	Route du Simplon 16	CH-1094 Paudex	+41 (0) 21 / 7 93 20 32		
	Reiherweg 2	CH-5034 Suhr	+41 (0) 62 / 8 55 60 60		
	Baslerstrasse 30	CH-8048 Zürich	+41 (0) 43 / 3 44 12 12		

❖ Events	
April 21, 2026	Quarterly report Q1/2026
May 12, 2026	Shareholders' meeting
July 21, 2026	Half year report 2026
October 20, 2026	Quarterly report Q3/2026
March 16, 2027	Annual report 2026

Investor contact

Mensch und Maschine Software SE
 Markus Pech, CFO
 Argelsrieder Feld 5
 D-82234 Wessling

Phone +49 (0) 81 53 / 9 33 - 0
 Telefax +49 (0) 81 53 / 9 33 - 1 00
 E-Mail investor-relations@mum.de
 Internet www.mum.de/investor

❖ Addresses					
Company	Street	Town	Telephone	Telefax	Internet
Man and Machine Frankreich	141/45 Boulevard Romain Rolland	75014 Paris	+33 (0) 1 / 53 72 88 00	+33 (0) 1 / 53 72 88 01	www.manandmachine.fr
Man and Machine UK	Unit 8 Thame 40 Jane Morbey Road, Thame,	Oxfordshire, OX9 3RR	+44 (0) 18 44 / 26 18 72	+44 (0) 18 44 / 21 67 37	www.manandmachine.co.uk
Man and Machine Italien	Via Torri Bianche, 1 Corso Unione Sovietica, 612/20 Via Umberti Forti 1 - Mantacchiello	20871 Vimercate (MI) 10135 Torino (TO) 56121 Pisa (PI)	+39 (0) 39 / 6 99 94 1 +39 (0) 11 / 34 71 838 +39 (0) 50 / 9 65 61 62	+39 (0) 39 / 6 99 94 44 +39 (0) 11 / 3 47 31 77 +39 (0) 39 / 6 99 94 44	www.mum.it
Man and Machine Polen	ul. Zeromskiego 52	90-626 Lodz	+48 (0) 42 / 2 91 33 33		www.mum.pl
Man and Machine Rumänien	Str. Remus Nr. 12, Sector 3	030685 Bucuresti	+40 (0) 31 / 2 28 80 88	+40 (0) 31 / 28 80 91	www.manandmachine.ro
Mensch und Maschine Ungarn	Fenyves sor. 7	9400 Sopron	+36 (0) 99 / 330 300		www.mum.co.h
Mensch und Maschine Mechatronik GmbH	Öschstraße 33	D-73072 Donzdorf	+49 (0) 71 62 / 94 97 85 - 0	+49 (0) 71 62 / 94 97 85 - 10	www.mum.de
DATAflor Software AG	August-Spindler-Straße 20	D-37079 Göttingen	+49 (0) 5 51 / 5 06 65 - 50	+49 (0) 5 51 / 5 06 65 - 59	www.dataflor.de
SOFISTIK AG	Parkring 2	D-85748 Garching	+49 (0) 89 31 58 78 - 0		www.sofistik.de
SOFISTIK AG	Flataustraße 14	D-90411 Nürnberg	+49 (0) 911 39 901 - 0		www.sofistik.de
OPEN MIND Technologies AG	Argelsrieder Feld 5	D-82234 Wessling	+49 (0) 81 53 / 93 35 00	+49 (0) 81 53 / 93 35 01	www.openmind-tech.com
OPEN MIND Technologies Schweiz GmbH	Frauenfelderstrasse 37	CH-9545 Wängi	+41 (0) 44 / 8 60 30 50	+41 (0) 44 / 8 60 30 51	www.openmind-tech.com
OPEN MIND Technologies UK Ltd.	Unit 3, Bicester Business Park Telford Road – Bicester	Oxfordshire OX26 4LN	+44 (0) 18 69 / 29 00 03		www.openmind-tech.com
OPEN MIND Technologies Italia S.r.l.	Via Pomè 14	20017 Rho (MI)	+39 / (0) 2 / 93 16 25 03	+39 / (0) 2 / 93 18 44 29	www.openmind-tech.com
OPEN MIND Technologies France S.a.r.l.	3, avenue Edouard Herriot, Parc Elitech, Bat B	69400 Limas	+33 (0) 4 / 87 01 85 01	+33 (0) 4 / 84 50 80 71	www.openmind-tech.com
OPEN MIND Technologies Spain, S.L.U.	C/ Vilarós nº5, D3	08022 Barcelona	+34 (0) 932 17 80 50		www.openmind-tech.com
OPEN MIND Technologies Portugal Unipessoal, LDA	Edifício Centro de Negócios MAPER, Fração N e O, Estr. Nacional 242, Km 9,2	2430-074 Marinha Grande	+351 244 023 359		www.openmind-tech.com
OPEN MIND Technologies Asia Pacific Pte Ltd.	MOVA Building, 22 Jalan Kilang	03-00 Singapore 159419	+65 67 42 95 56		www.openmind-tech.com
OPEN MIND Technologies Japan K.K.	Albergo Musashino B101, 3-2-1 Nishikubo, Musashino-shi	180-0013 Tokyo	+81 50 53 70 10 18		www.openmind-tech.com
OPEN MIND CAD/CAM Technologies India Private Ltd	#610&611, 6st Floor, 'B' Wing, No.6 Mittal Tower, M.G. Road	Bangalore 560 001	+91 80 26 76 69 99	+91 80 26 76 92 16	www.openmind-tech.com
OPEN MIND Technologies Taiwan Inc.	Room F, 4th Floor, No.1, Yuandong Rd. New Taipei City 22063	Taiwan, R.O.C.	+886 2 29 57 68 98	+886 2 29 57 68 08	www.openmind-tech.com
OPEN MIND Technologies China Co.Ltd	Suite 1608, Zhong Rong International Plaza No.1088 South Pudong Road	Shanghai 200120	+86 21 58 87 65 72	+86 21 58 87 65 73	www.openmind-tech.com
OPEN MIND Technologies USA, Inc.	1492 Highland Avenue, Unit 3	Needham MA 02492	+1 (888) 516 12 32	+1 (270) 912 - 58 22	www.openmind-tech.com
OPEN MIND Tecnologia Brasil LTDA	Av. Andromeda, 885 SL2021	06473-000 – Alphaville Empresarial Barueri – Sao Paulo	+55 11 24 24 85 80	+55 11 24 24 85 81	www.openmind-tech.com
OPEN MIND Technologies Benelux BV	Titaniumlaan 86	5221 CK 's-Hertogenbosch	+31 73 6480-166	+31 73 6480-169	www.openmind-tech.com
OPEN MIND Technologies Scandinavia AB	C/O ISO Tool AB Enhörningsvägen 8 A	281 43 Hässleholm			www.openmind-tech.com
Hummingbird Systems GmbH	Einsteinstraße 152	91074 Herzogenaurach	+49 911 237 94 60		www.hummingbird-systems.com

CAD/CAM in practice: Intelligent AI access to legacy production data

Customers: Production companies that want to leverage their CAM knowledge

Artificial intelligence brings hidden legacy knowledge back to light:

A large amount of data and thus considerable know-how has been developed in the production plants over the years. Since this treasure of experience is hidden deep in the archives, it is not directly accessible and can be used for new tasks only with considerable effort.

M+M's new AI-based *hyperMILL* DataCenter solution enables a quick access to all historical production data. For this purpose, a specially trained AI model will be optimized based on customer data so that all historical data can be made available quickly using a browser. When users want to produce a new part, it's very easy to find similar parts in the historical database, so that all technical decisions and machining strategies can be derived easily for the new project.

This increases effectiveness enormously. All data is stored and protected in a private cloud and every new production part can be easily added, so that the treasure of production knowledge is constantly expanding. For our customers, this prompt access to their own data is essential for a fast and reliable quotation.

hyperMILL®

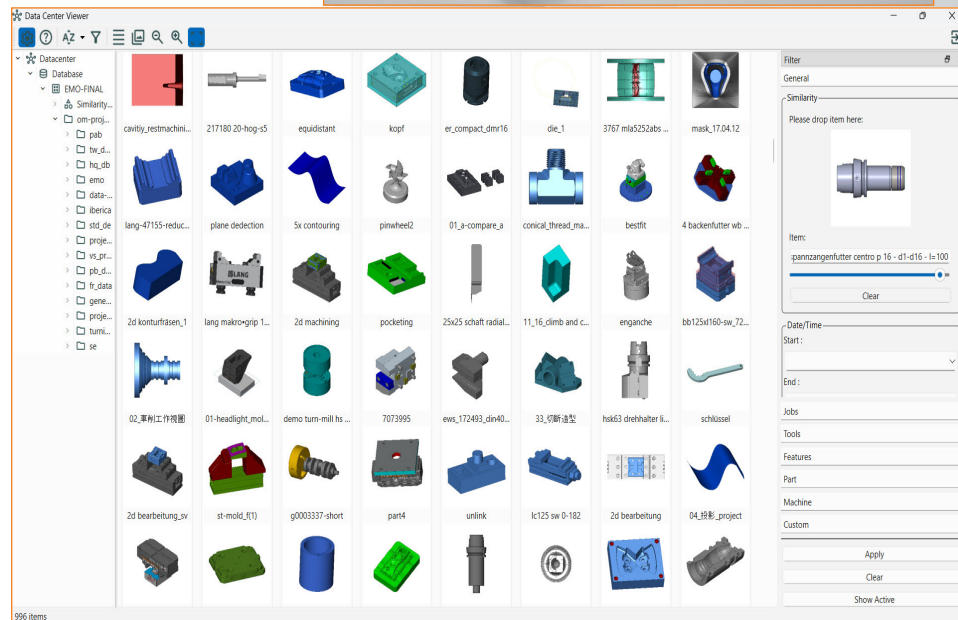
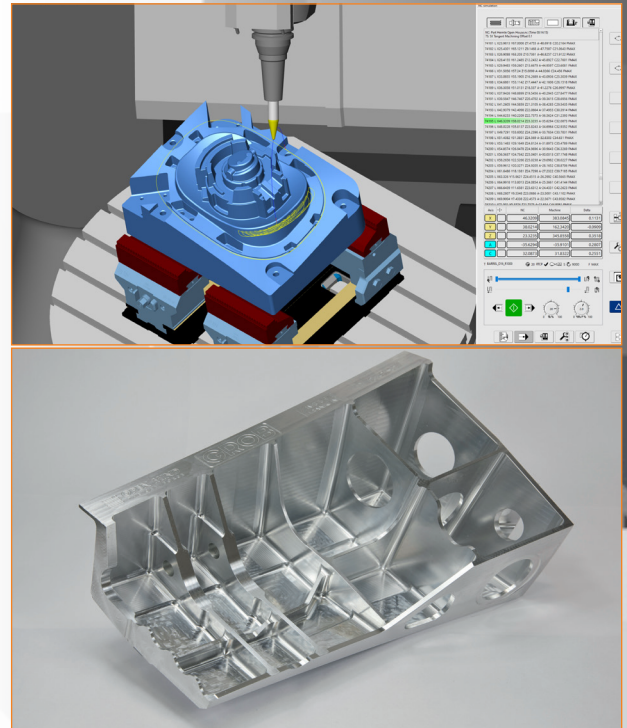

mensch  **maschine**
Software

Mensch und Maschine

Software SE

Argelsrieder Feld 5

D-82234 Wessling

Tel. +49 (0) 81 53 / 9 33 - 0

Fax +49 (0) 81 53 / 9 33 - 100

www.mum.de

Cover picture "Digital Twin":
Milling simulation of an engine block
on a 5-axis portal machine using
hyperMILL VIRTUAL MACHINING