 Mensch und Maschine at a glance

All amounts in million EUR (unless stated otherwise)	2000	2001	2002	2003	2004
Revenue	115.8	146.8 +27%	143.1 -2.5%	131.0 -8.5%	135.5 +3.4%
Germany	50.3 43%	56.6 39%	55.1 38%	48.1 37%	41.5 31%
International	65.5 57%	90.2 61%	88.1 62%	82.9 63%	94.0 69%
Revenue per share in EUR	13.33	16.54 +24%	14.19 -14%	12.80 -10%	12.35 -4%
Gross Margin	31.0	40.0 +29%	47.2 +18%	42.5 -10%	42.6 +0.4%
Trading products	25.2 81%	31.6 79%	25.1 53%	21.3 50%	20.2 47%
M+M Technology + Services	5.8 19%	8.5 21%	22.1 47%	21.2 50%	22.4 53%
Operating result EBITA	4.8	7.8	-7.9	-5.0	1.9
EBITA return from revenue	4.1%	5.3%	-5.5%	-3.8%	1.4%
Net result	1.6	2.3	-14.3	-6.3	-9.3
Net return from revenue	1.3%	1.6%	-10.0%	-4.8%	-6.8%
Net result per share in EUR	0.19	0.27	-1.42	-0.62	-0.84
Dividend in EUR	0.14	0.18	0.00	0.00	0.00
Total assets	80.8	89.2 +10%	83.2 -7%	80.1 -4%	69.1 -14%
Shareholders' equity	24.9	27.8 +11%	17.8 -36%	14.8 -17%	8.7 -41%
Capital ratio	30.8%	31.1%	21.3%	18.5%	12.6%
Number of shares in millions	8.692	8.966 +2%	10.084 +14%	10.232 +1%	10.972 +7%
Number of employees	228	298 +31%	467 +57%	405 -13%	355 -12%
thereof M+M AG	98	88 29%	89 19%	89 22%	79 22%
International subsidiaries	104	136 46%	141 30%	120 30%	102 29%
Technology subsidiaries	26	74 25%	237 51%	196 48%	174 49%

Dear reader,

Mensch und Maschine Software AG (M+M) has completed its twentieth year since foundation positively, with a leap in operating result, and has returned to a growth path following two years of consolidation.

This was effected through a combination of reduced operating expenses and increased income. Thus M+M has harvested the first fruit consequent to a three year restructuring policy, during which the expense base was lowered by more than ten million Euro. This will have a positive ongoing impact on expense limitation in the years to come, due to delayed effects.

The development of business distribution as a result of the Three Pillar Strategy was also very pleasing. The gross margin share from M+M Technology climbed to 53% and the youngest unit PTC improved its share to 12%, while the formerly dominant Autodesk unit has settled at a 35% share as predicted.

This makes us very confident for the new fiscal year, during which we expect a continuation of moderate growth and a further jump in operating result due to lower expenses.

This optimism is underlined by the successful sale of our PLM subsidiary COMPASS to Autodesk, signed in February 2005, creating a cash inflow of approximately EUR 7 million which will mainly be used for the further reduction of bank debt.

After a dynamic growth and investment phase since the IPO in 1997, followed by three years of consolidation beginning 2002, M+M is now entering a harvesting phase with sustained cash inflows.

To support this, we cleaned up the balance sheet on Dec 31, 2004. This has resulted in another high book loss for 2004 on one hand, but consequently relieves the years to come on the other.

For 2005, we estimate sales amounting to EUR 145 mln along with net earnings of EUR 6 mln or EUR 0.50 per share, coming half from the operating business and half from the Compass disinvestment.

For the following fiscal year 2006 we are heading to surpass the old revenue and earnings record benchmarks in order to enable our share price to go further north.

Wessling, March 2005
The Board of Management

2004 at a glance

- Revenue EUR 135.5 mln (+3.4%)
 - International share 69% (PY 63%)
 - Annual growth rate 1997-2004: 15%
- Gross margin EUR 42.6 mln (+0.4%)
 - M+M Technology share: 53%
- Operating expenses lowered by 7%
- Leap in operating result EBITA:
 - EUR 1.9 mln (PY -5.0)
- Positive operating cashflow
- Bank debt further reduced
- Subsidiary COMPASS will be sold
 - Cash inflow approx. EUR 7 mln, net profit approx. EUR 3 mln
- Restructuring completed
 - Balance sheet clean up concerning goodwill and tax assets
 - Relief for future fiscal years

Events

May 6, 2005	Quarterly report Q1/2005
June 7, 2005	Annual shareholders' meeting
August 8, 2005	Half year report 2005
November 14, 2005	Quarterly report Q3/2005
March 20, 2006	Annual report 2005
March 20, 2006	Analysts' conference

Management report

Enterprise and market position

Mensch und Maschine Software AG (M+M) is one of the leading European providers of CAD (Computer Aided Design) solutions.

The good customer and industry sector balance however originated from the early business model, following M+M's foundation in 1984.

Well balanced business model

The M+M business model has a relatively broad base within the CAD market and is equally balanced in three respects:

1. Geographical markets
2. Customers and industry sectors
3. Product portfolio

The distribution over various geographical markets was mainly achieved in the years after the 1997 M+M IPO by a dynamic international expansion.

The product portfolio, which until 1999 had been rather unilaterally focused on Value-Added Distribution (VAD) of standard CAD software from US vendor Autodesk, was evened out during the last two years, mainly by a strong growth push in the business unit "M+M Technologies and Services" and by starting sales of a second standard CAD software from vendor PTC.

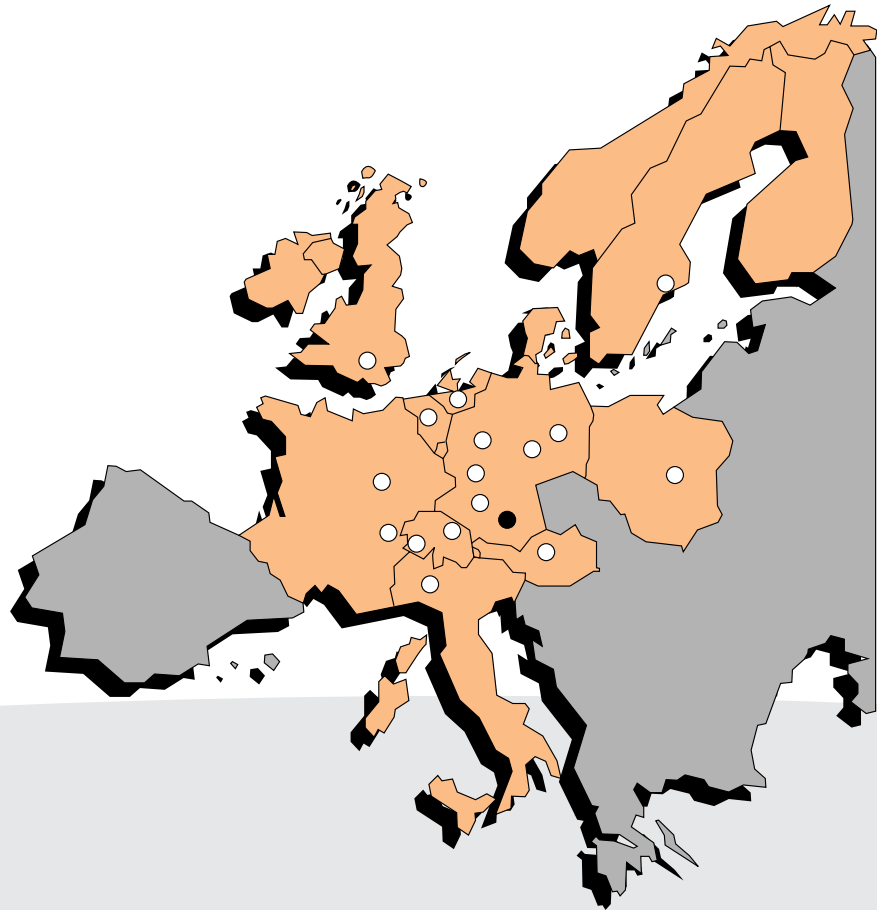

1. Geographical markets

While in 1997 domestic German business was clearly dominant with international sales of only EUR 12.7 mln or 25% of group revenue, the following years saw a multiplication of international business which in fiscal year 2004 amounted to EUR 93.9 mln or 69% of total group sales.

This development was driven by acquisitions in France, Italy, Poland (all 1998), England, Sweden (2000) and Switzerland (2001) as well as by the foundation of a new subsidiary in Belgium (2002) which today gives M+M market access to 15 European countries. Additionally, there are sales offices in the USA, Japan and Singapore, exclusively marketing M+M Technology.

2. Customers and industry sectors

In this respect, the M+M business is split about half into mechanical engineering and half into the sectors of architecture and the construction industry with building services and visualization (approx. 25%), GIS - Geographic Information Systems / gardening and landscaping (approx. 15%) and electrical engineering (approx. 10%).

This distribution is quite similar to the global CAD market, where about 50% of the total market volume is attributed to mechanical.

Customer and orderwise the distribution of business is even wider. M+M is selling software solutions for about 50,000 CAD seats per year, mainly through a network of approximately 1,000 authorized resellers, none of whom is achieving more than 3% of M+M group sales. Consequently there are no deep dependencies on the customer side from single purchasers.

Together with the reseller network, Mensch und Maschine has built up an installed base of over 450,000 CAD seats at about 50,000 end customer sites of all size categories - from small engineer's or architect's offices up to international large-scale enterprises.

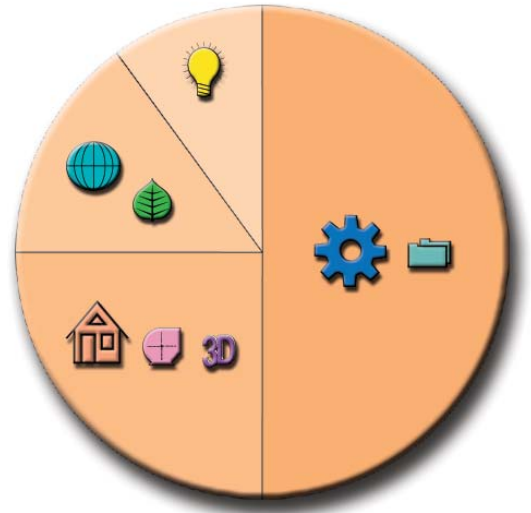

The M+M group's business divides into four industry segments: One half of the sales is achieved with mechanical engineering and PLM (Product Lifecycle Management) solutions. The other half consists of architecture / construction industry (approx. 25%) including building services and visualization, Geographic Information Systems (GIS) / gardening and landscaping (approx. 15%) and the electrical engineering segment contributing approx. 10% of sales.

3. Product portfolio

The M+M product portfolio covers a wide price/performance range from simple drawing software costing a few hundred Euros through midprice 2D/3D design solutions in the four-digit Euro range up to high end systems for manufacturing and production control with software investment costs from 10,000 to 100,000 Euros and more per seat. The majority of sales is generated in the midprice range.

Until 1999, only about 10% of the group gross margin was achieved with M+M Technologies and Services, while the VAD business unit was clearly dominant and marked a relatively strong dependence upon main supplier Autodesk.

The M+M Technology gross margin share grew significantly during the last few years and amounted to EUR 22.4 mln or 53% of group gross margin in fiscal year 2004. Thus the M+M business model is now balanced across the product portfolio between owned and trading products. This was possible through a Technology Offensive, in the course of which several software developers, fitting to the M+M core business, had been acquired during 2001 and 2002. In most of these companies, M+M already had strategic minority shareholdings.

Development towards three pillar strategy

Due to the Technology Offensive, an equal balance across the product portfolio on two pillars was achieved. Based on this, the M+M business model was further extended, on the product side, with the new three pillar strategy beginning 2003. To achieve this, a contract was completed with Parametric Technology Corporation (PTC). This company, which like Autodesk (ticker symbol ADSK) is listed on Nasdaq (ticker symbol PMTC), also has a leading position with mechanical CAD software. In spring 2003, PTC released the product line, Pro/ENGINEER Wildfire™, which M+M from March 1, 2003 took over the Value-Added Distribution.

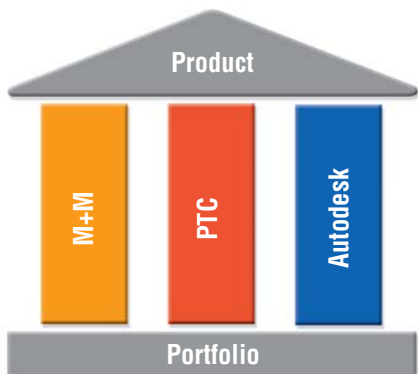

*Three pillar strategy for product portfolio:
After evenly balancing the business between M+M Technology&Services and Value-Added Distribution of Autodesk software, following the Technology Offensive, the addition of PTC software has added a third pillar to the product portfolio from 2003 onwards.*

As expected:

Little competition between Autodesk and PTC

Introducing a second supplier in no way meant that M+M was turning away from Autodesk its long term primary supplier, whose products continue to play a key role in M+M's portfolio. Autodesk remained an important partner of M+M in the areas of architecture/ construction, geography, and electrical as well as mechanical engineering.

As expected, there is very little direct competition between Autodesk and PTC software, because firstly both portfolios just overlap in the mid

price range and in the 3D mechanical sector, and secondly because the largest part of the business today is achieved with existing customers or in the environment of the installed base, e.g. with the supply industry, meaning that most prospects have a natural preference for one or the other portfolio.

In 2004, the total gross margin generated in the VAD business amounted to EUR 20.2 mln representing a 47% share in group gross margin. Thereof an amount of EUR 14.9 mln / 35% was contributed by Autodesk and EUR 5.3 Mio / 12% by PTC distribution.

Approximately 53% of the 2004 gross margin was achieved with M+M group's own brands. The newest PTC segment has contributed 12%, while the Autodesk share was reduced to 35% as planned.

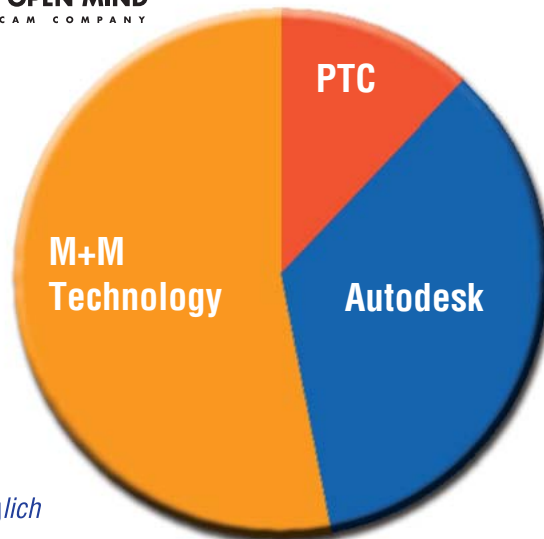

Balance between Software Development and Value-Added Distribution

While the VAD segment gives M+M broad market access and contributes 80% of sales, the self-developed technologies are responsible for the differentiation potential and give the M+M group an individual market profile, clearly distinguishable from its competition.

In the "M+M Technology" segment, M+M is a standard software developer with a gross margin yield of 85% (compared to almost 20% yield in the VAD segment) and concentrates on sector and niche applications which are not covered by the large vendors like Autodesk, PTC or Dassault. 90% of the group revenue in this segment was generated by the six technology and service subsidiaries OPEN MIND, ECS, DATAflor, M+M Akademie, EUKLID and COMPASS, the remainder comes from the product brands RoCAD and CAD*erschwinglich* ("CAD affordable") which are developed by the group mother company, M+M AG.

The M+M product brands

The individual technology subsidiaries and M+M group product brands are introduced as follows.

OPEN MIND Technologies AG

Group member since Q1/2002 (100%)

OPEN MIND specializes on CAM software solutions. CAM stands for Computer Aided Manufacturing, e.g. the automatic milling of moulds for casting and forging in the Automotive and Aerospace industry as well as in many other areas of Mechanical Engineering. Especially in the highly complex 5-axis milling process, the hyperMILL product line from OPEN MIND, has a technologically leading position and allows the customers quick amortization of their high machine tool investments.

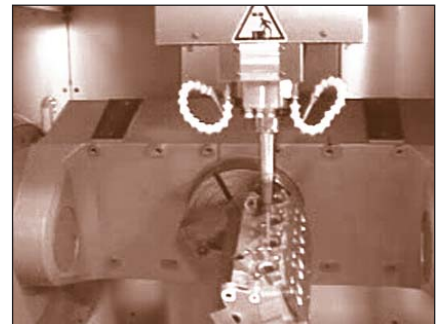

*Application example CAM:
Milling of a cylinderhead with hyperMILL
from OPEN MIND (see also cover pages)*

With the patented "tube milling process", hyperMILL enables the fully automatic milling of induction ports with very short cutters which are much more stable. With this method, the manufacturing time for a cylinder head can be dramatically reduced. This solution is, among others, in use by several Formula 1 race teams.

Another highly complex application is the milling of impellers, where the programming and manufacturing time is reduced significantly by new algorithms. In this area, OPEN MIND closed cooperation and sales agreements with renowned precision machine tool manufacturers.

The second product line hyperFACT is used in production control, e.g. assisting to achieve high productivity gains in motor manufacturing.

The M+M CAM solutions are not only sold in Europe, but also, through subsidiaries, in the USA, Asia/Pacific and Japan. With sales of approximately EUR 13 mln, the M+M group belongs to the first tier of vendors in the important niche market of CAM solutions.

Elektro-CAE Software GmbH (ECS)
Group member since Q1/2002 (60%), since 1998 minority shareholding

ECS is the developer of ecscad, a leading electrical engineering application in the Autodesk world, being exclusively marketed by the M+M group for 10 years.

The emphasis in electrical engineering solutions is not in the graphical but in the data base area. Ecscad has its special strength here. Large electrical engineering projects, e.g. at railroad companies, contain up to a thousand or more diagrams which are interlinked by very extensive cross references with each other.

These cross references are managed automatically by ecscad in a special database. As a result, the potential for rationalization for such customers is particularly high. ECS solutions are not only marketed in Europe but are also sold in the USA and in Asia through local distribution and OEM partnerships under the product names Promis-e and RS-Wire.

About 20,000 installations of ecscad and its sister brands are existing in all areas of the mechanical and electrical industry. To address even more customers in the future, new modules are constantly being developed, e.g. for the special requirements of TV studios or the energy supply industry.

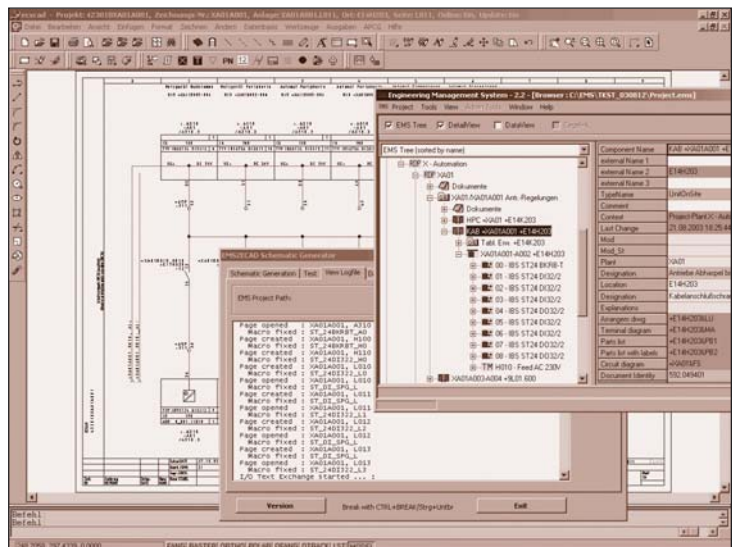

Application example Electrical Engineering: ALSTOM Power Conversion GmbH are integrating ecscad with their Engineering Management System

DATAflor Software AG

Group member since Q1/2002 (61.5%),
since 1999 minority shareholding

DATAflor has a strong position in the German-speaking gardening and landscaping market for garden and landscape architects as well as garden centers. The proffered solutions not only contain a graphical planning part but also complete financial calculation and billing of such projects. DATAflor was founded back in 1983 and maintains evolved customer relationships which are carefully nurtured.

This enabled DATAflor to hold nearly stable sales in spite of difficult market economies in the past years and even enhance their already high market share in this niche market.

RoCAD for building services

The building service solution RoCAD, developed by the mother company M+M AG, holds an important market position in the Autodesk environment, mainly in the German speaking area with about 2,000 installations. RoCAD supplies 2D and 3D solutions for the design and construction of heating, air conditioning, plumbing and electricity. Similar to ecscad, the scope of use and customer group potential is constantly extended by development of special modules, e.g. for the calculation of energy and heating requirements.

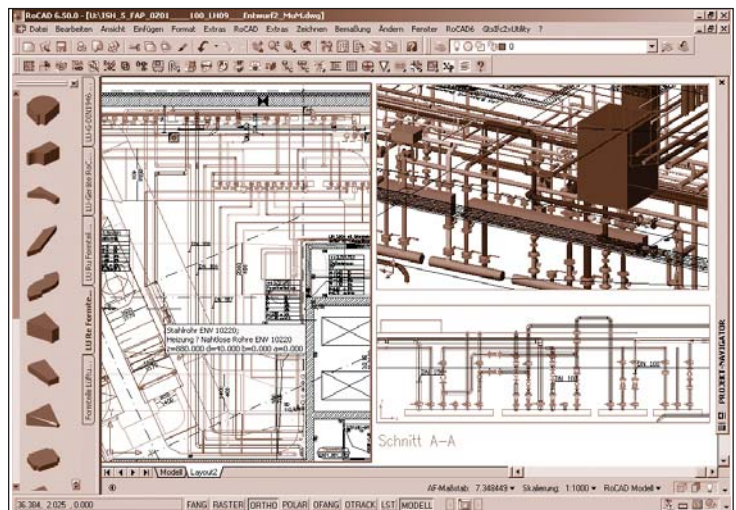

Application example building services: The Königsbau Arcades in Stuttgart – design of technical control center with RoCAD by engineer's office Scheer

CADerschwänglich product lines

The CADerschwänglich (CAD affordable) low price product lines have a long inhouse tradition at M+M.

Symbols and parts libraries

From 1988 onwards, M+M has developed symbols and parts libraries, also called “electronic stencils”, offering the CAD user lots of standard parts and symbols for very little money. Currently, the collection includes 26,000 symbols and parts, being edited in 11 library packages, which cover a broad sector bandwidth and are used for illustration of documents of any kind, not only in CAD systems but also in Microsoft Office.

At a list price of 60 Euros (+VAT) and about 200,000 copies sold, the libraries are the lowest cost, as well as the highest volume, products made by M+M.

Also in 2004, approximately 11,500 copies were sold.



AutoCADmenu and ADT series

Priced above the libraries, there are two other CADerschwänglich product lines. With AutoCADmenu, M+M offers low cost user interfaces and applications for 150 to 300 Euros (+VAT), making the daily drafting work easier for mechanical or architectural users as well being compatible with the M+M symbols and parts libraries.

Last but not least, the latest “ADT” product series, consisting of *Elements*, *Umbau*, *Massen* and *Energy*, offers the user of Autodesk Architectural Desktop (ADT) supplementary tools for 250 to 390 Euros (+VAT) each.

Elements is a collection of more than 10,000 2D and 3D architectural elements plus approx. 1,000 materials, surface styles and hatching patterns. *Umbau* supports the user particularly for restructuring and renovation projects, while *Massen* and *Energy* are supporting the mass calculation for the estimation and bidding process and the room catalogue and the heat requirement calculation for buildings, respectively.

Mensch und Maschine Akademie GmbH

Group member since 1999 (100%),
since 1998 minority shareholding

M+M Akademie is the only pure service subsidiary in the group concentrating on the areas of training and customer-specific software applications. In 2004, software projects for important customers like Porsche, Siemens oder Deutsche Bahn were executed and approximately 1,500 people were trained.

EUKLID Software GmbH

Group member since Q2/2001 (100%),
since 2000 minority shareholding

The EUKLID business in the CAD/CAM area has been more and more transferred to OPEN MIND during the past years. In parallel, headcount and expenses were reduced dramatically. At the end of 2004, the CAM product line was sold, removing the former overlap with the OPEN MIND product portfolio. The remaining product lines in the CAD area (EUKLID Design and NesCAD) remain under support and releasing. Due to the partial sale, an impairment on the EUKLID goodwill was booked in 2004.

COMPASS Systems GmbH

Group member since Q2/2002 (50.1%),
since 1999 minority shareholding
Sale of all assets to Autodesk is expected to be closed by the end of March 2005

With nearly 20,000 installations of the COMPASS product line at approximately 1,800 customers, a strong position is held for PDM/PLM solutions, mainly in the German speaking area, but increasingly in other countries of Europe.

PDM/PLM means Product Data/Lifecycle Management, i.e. the database-management of product-related data throughout the whole design process and product lifecycle. COMPASS users mainly come from the mechanical engineering sector and appreciate the particular suitability of the system in heterogeneous CAD environments as well as the ease of use in small to medium-size workgroups, keeping project costs monitored and allowing fast project development.

On February 18, 2005, Autodesk and M+M announced a binding contract concerning the purchase of the entire COMPASS GmbH assets by Autodesk, who will also take over all employees including the founders and minority shareholders. Closing of the definite agreement now signed is expected in March of 2005.



With this sale, M+M is realizing a cash inflow amounting to approx. EUR 7 mln and a net book profit amounting to approx. EUR 3 mln. The sale of the development activities does not mean the removal of the Compass solutions from the M+M offering portfolio, but M+M will continue to sell them within the Autodesk VAD segment.

Strategic minority shareholdings

In addition to the technology subsidiaries, M+M is holding five strategic minority shares rounding up the market position in some niche markets.

In the architecture/construction area M+M holds shares in CTB GmbH & Co KG, Buchholz near Hamburg (M+M share 19.9%) and in SOFiSTiK AG, Oberschleissheim/Nuremberg (M+M share 14.3%). CTB and SOFiSTiK are both offering high-quality software solutions for architecture, civil engineering and statics.

In the GIS field there is a 20% shareholding in C-Plan AG, Muri near Berne, Switzerland. C-Plan develops under the brand name Topobase complete solutions for local governments as well as energy suppliers and is successfully selling them in Switzerland and Germany, as well as increasingly in other European countries.

Further shares are held in YELLO! AG, Wiesbaden (M+M share 29.3%), offering visualization and animation solutions mainly for TV stations and studios, and in CYCO BV, Netherlands (M+M share 7.4%), a supplier of EDM (Engineering Document Management) in the Autodesk market environment.

Large target market CAD software and service

The worldwide market for CAD software and service has an annual sales volume of about EUR 10 billion (Sources: Daratech, Dressler-Verlag, own) and is segmented into mechanical engineering, PLM, architectural/construction, geography, electrical engineering, electronic and structural analysis. Except for the latter two, M+M covers all of the segments.

The volume of M+M's main market, Europe, thus is just over 3 bln EUR, meaning that M+M reaches a direct market share of 4-5%. The indirect market share, equal to the revenue volume of the M+M reseller network in the market, is in the range of 10%, because the resellers' sales multiple is estimated to be in the order of magnitude of 2 to 2.5.

Protecting and expanding the market position

Totalling EUR 26.7 mln in 2004, sales and marketing continued to hold the largest share (61.5%) in group operating expenses. This sum contains personnel expenses amounting to EUR 13.8 mln and other expenses amounting to EUR 12.0 mln, primarily used for advertisements, trade shows and other marketing activities to protect and expand M+M's market position.

Marketing budget concurrently optimized

The marketing area is continuously optimized in order to reach as many potential customers as possible with the funds spent. The trend for trade shows has been to be present at more shows whilst using a lower budget per stand (in 2004 M+M attended 69 shows in 15 countries). As an indirect vendor, M+M is attending trade shows usually partnering suitable resellers. Like all marketing activities offered by M+M, the resellers' trade show expenses are settled via the "PR-Pool", a revenue-driven marketing fund for authorized M+M partners.

M+M Magazine reaching 200,000 customers

Through a carefully maintained address database, the customer newspaper "M+M Magazine" reaches about 200,000 existing and potential customers. In 2004, altogether 24 issues in four languages were published with a total number of 370,000 copies.

High focus on address qualification and CRM

Nothing is more wasteful than trawling through unqualified or duplicated addresses. Therefore the address database is continuously maintained through a web-based CRM system (Customer Relationship Management) and focused use of tele-marketing activities for, as far as possible, actuality of data and compactness. As well, an efficient and timely distribution of prospects' leads within the M+M reseller network is essential - including tough control of the resellers' performance to make sure that requests from end users are answered quickly and to the best standard possible.

Strong focus on IT and backoffice

A prerequisite for the efficient use of marketing funds, as well as for a well-functioning supply chain, is an optimized IT and backoffice system.



SAP R/3 and integrated CRM system

Since 1997, M+M has used the ERP system SAP R/3, which in the meantime has been introduced in nearly all group companies. Building on this, a web-based CRM system, fully integrated in SAP R/3, was introduced and adapted to the various sales and marketing tasks in the group during the past years.

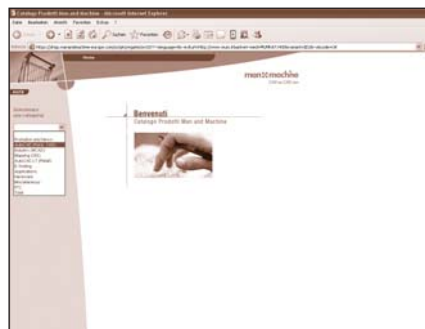

More than 60% of orders through web-shop

Along with the growing integration of the individual components, the processes could be optimized. E.g. more than 60% of all orders are coming in electronically through the internet, because customers can use web-shops for comfortable ordering round the clock. There is a closed shop for authorized resellers, fully integrated in SAP R/3, and an open shop for end customers in the low-price sector (*CADerschwänglich*). Additionally, resellers can lease a shop via "shop hosting" from M+M, enabling them to present their product and service portfolio under their own corporate identity and transfer the appropriate part of the incoming orders to M+M at a fingertip.

Integration with suppliers and customers ...

The mid range goal in the IT/backoffice area is the full integration of the supply chain in order to further save processing costs and eliminate error sources. This requires an electronic interface not only on the customer but also on the supplier side (Supply Chain Management - SCM). The main suppliers Autodesk and PTC are already interfaced as far as possible, these interfaces will be continuously completed in the course of 2005.

... will drive up electronic order entry quota

Following this, the connection to larger resellers using inhouse ERP systems is targeted. This will allow the electronic order entry quota to further accelerate towards 100%, opening high cost saving potentials for M+M as well as for customers and suppliers.

High ongoing development investments ...

With a total amount of EUR 7.6 mln or around 17.5% of operating expenses in 2004, research and development again represented a significant cost position in the M+M group. These funds were used by the group mother company and the technology subsidiaries for the maintenance and development of M+M software products.

... are not capitalized: software library is a hidden reserve

Capitalization of development costs according to IAS 38.45 is not applied by M+M, meaning that the extensive software basis of the group containing hundreds of man years of invested development power represents a hidden reserve.

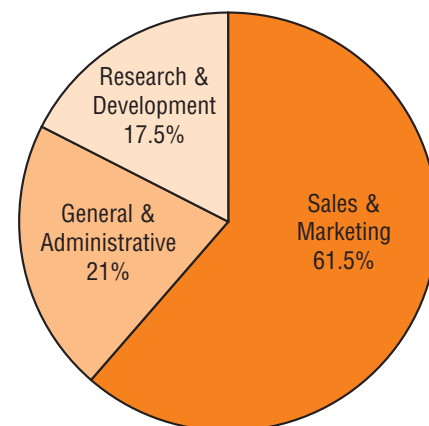

The distribution of operating expenses in the M+M group shows a clear dominance of sales and marketing expenses.

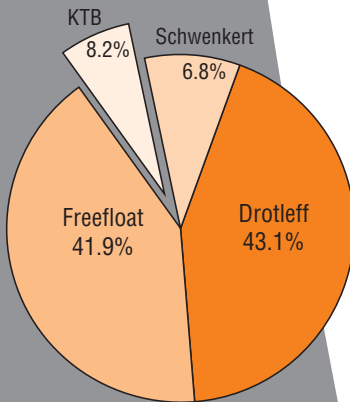

Employees are co-entrepreneurs

Traditionally, there is a very high focus on good corporate culture at M+M. During the 21 years since foundation of the company in 1984, the employees were always seen as "Co-Entrepreneurs" and fully integrated in the decision making process. Whenever acquiring companies in and outside Germany in the course of the intensive expansion since IPO in 1997, M+M always cared for and respected the specific culture of the companies acquired and encouraged them to adopt M+M corporate culture very gently. The decision making structures in the M+M group are as decentral as possible, the individual entities have a high degree of responsibility in order to achieve the best possible results in the individual markets and to be able to optimally meet the customers' requirements.

Experienced management team

This corporate culture generated a high degree of continuity. Fluctuation in the M+M group is very low, which especially during the hype phase of the IT industry at the end of the 90's prevented a drain of qualified specialists from which other similar companies in IT suffered. As a result, M+M has an experienced management team down to the second and third management level, with team members mostly looking back on an employment period of more than 10 years.

Public and private company

Though M+M shares are listed on the stock market for eight years, the majority of the shares are still in the hands of the management board. Founder and CEO Adi Drotleff holds approximately 5.2 million shares or 43.1% of the approximately 12 million shares outstanding at Dec 31, 2004. A package of 820,000 shares is owned by CTO Werner Schwenkert. This was created from the acquisition of OPEN MIND AG by the M+M group through a share swap.

The free float at Dec 31, 2004, contained about 5.0 million shares or 41.9%. A certain part thereof was held in smaller packages by other members of the management board or the next management levels. M+M thus can be seen as a public and a private company in one. This is also documented in the acceptance of responsibility for the company by the share-owning officers: Both are guaranteeing bank credits of the group, Adi Drotleff additionally granted M+M AG an interest-free loan and signed a part of the convertible loan, in order to strengthen the financial power of the group.

At December 30, 2004, KTB Technologie Beteiligungsgesellschaft mbh & Co KG subscribed a package of almost 1.0 mln shares (8,2%) from a capital increase. KTB, who has a medium to long term investment horizon, is a SME industrial holding headquartered in Hannover, jointly held by a private family holding and tbg, a subsidiary of Kreditanstalt für Wiederaufbau (KfW), thus combining public and private money in financing small to mid-size enterprises.

Course of business 2004 and situation of the group

In fiscal year 2004, the M+M group could successfully complete two years of restructuring and remodelling of the business model in the course of the Three-Pillar-Strategy, returning to positive operating results and to the growth path.

A significant balance sheet clean up as of Dec 31, 2004, completes this development and enables the M+M group to have a fresh start into future fiscal years.

Return to sales growth after two years of consolidation

Revenues amounting to EUR 135.5 mln (PY: 131.0 / +3%) marked the return to the growth path which had been left two years ago. In spite of this consolidation, the continued annual growth rate (CAGR) in the seven years since the floatation in 1997 still averaged a remarkable 15 percent. The international share of revenue again climbed significantly to 69% after 63% in the previous year.

The strong revenue development since floatation is also significantly visible on a per share basis: Revenue per share climbed from EUR 6.67 in 1997 to EUR 12.35 in 2004 - an indication of the growth of inner value since floatation.

Return to typical quarterly seasonality

After the relatively flat sales seasonality in the previous year, 2004 saw the return to the seasonality which is normal for M+M: With a distribution of 28 / 22 / 22 / 28%, only the share of the first quarter was a bit higher than expected.

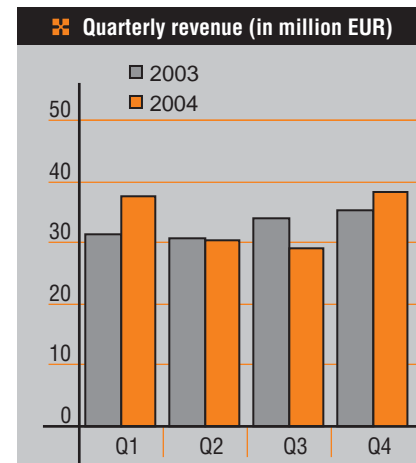
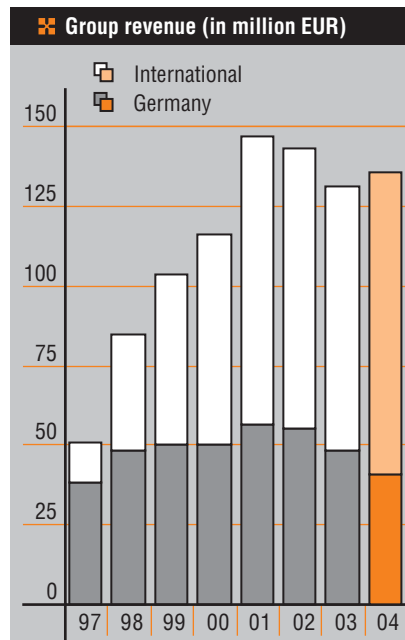

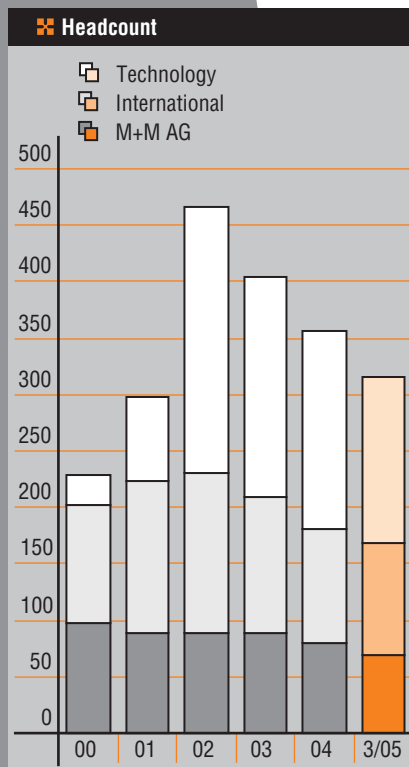

M+M Technology dominating

After deduction of purchased goods (VAD) or cost of production (M+M Technology), gross margin was nearly unchanged amounting to EUR 42.6 mln (PY: 42.5). Gross margin breakdown development was very pleasing: The share from M+M technology and service continued to increase to more than 53% (PY: 50%). In the trading product segment (VAD), contribution from the relatively young business unit PTC climbed to 12% (PY: 10%), while the Autodesk share decreased to 35% (PY: 40%) as estimated. In only five years since 1999, a 90 percent dependence on main supplier Autodesk could be turned into a good balance over the three pillars of the business model.

Headcount further reduced significantly

The number of employees, which had jumped from 298 to 467 between 2001 and 2002 in the course of the technology offensive and reduced by 13% to 405 through synergy, cost cutting and restructuring programs, decreased by another 12% to 355 on a 2004 yearly average.

In the meantime, the number of employees reduced even further to 343 at Dec 31, 2004, and - without the COMPASS employees - to only approximately 315 at March 31, 2005. Thereof 47% work for technology subsidiaries, 31% for international subsidiaries in the VAD business unit and 22% for the mother company, covering the segment VAD Germany and group holding functions.

Restructuring widely completed

Altogether, employment was reduced by 169 heads or 35% in three years since April 1, 2002, when after the first time consolidation of all new subsidiaries in the course of the technology offensive, a maximum of 484 employees had been reached. The restructuring is now widely completed with total costs amounting to EUR 6.0 mln (distributed to EUR 1.9 mln in 2002, EUR 2.2 mln in 2003 and EUR 1.9 mln in 2004).

Operating expense base significantly reduced

The operating expenses developed approximately in line with headcount. At first, the technology offensive caused a strong cost push with operating expenses including depreciation of fixed assets climbing from EUR 33.3 mln in 2001 to EUR 50.6 mln in 2002. The positive effects of synergy and the restructuring programme caused a reduction by 8% to EUR 46.7 mln in 2003 and by another 7% to EUR 43.4 mln in

2004. Due to delayed effects, further damping of operating expenses is estimated for 2005, resulting in a total reduction of the expense base by more than EUR 10 mln in three years. Additionally, there is another reduction by approx. EUR 3 mln caused by the COMPASS disinvestment.

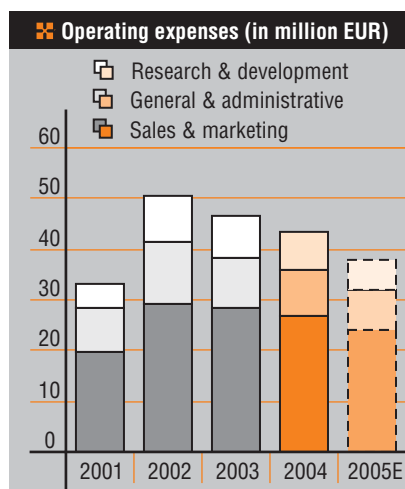

Restructuring costs ...

Restructuring costs in 2004 amounted to EUR 1.9 mln, as already mentioned. They are booked to other expenses and consisted about half each from headcount reduction costs and consulting fees for optimization of the group structure. In the previous year's EUR 2.6 mln, restructuring costs amounting to EUR 2.2 mln and other expenses amounting to EUR 0,4 mln are contained.

... are more than compensated by restructuring gains

On the other hand, there are restructuring gains amounting to EUR 2.9 mln (PY: 0), equally contributed by the sale of the EUKLID CAM product line and from the partial waiver at repayment of a bank loan. They were booked to other income totalling EUR 4.5 mln (PY: 1.7).

Leap in operating result EBITA

The operating result EBITA before interest, tax and impairment/amortization of goodwill improved significantly to EUR 1.9 mln, representing an EUR 6.9 mln leap over previous year's EUR -5.0 mln. EBITA contains depreciation of fixed assets amounting to EUR 1.4 mln (PY: 1.6), thus the operating result EBITDA before all depreciations and amortizations amounted to EUR 3.3 mln (PY: -3.4).

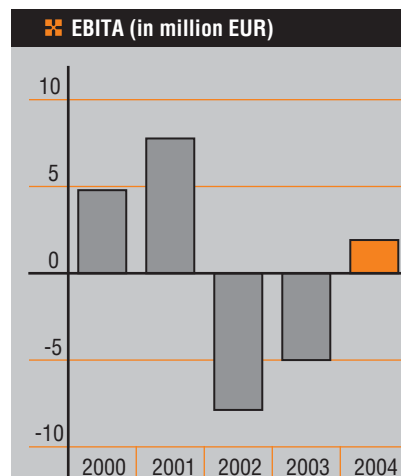

Goodwill impairment for EUKLID booked

Due to the reduced business volume of EUKLID GmbH after the portfolio reduction, a goodwill impairment amounting to EUR 3.0 mln was booked. In the previous year, amortization on total goodwill amounting to EUR 1.4 mln was booked, which is no longer applicable due to early adoption of IFRS 3 from 2004 on.

The operating result EBIT after all depreciations and restructuring effects amounted to EUR -1.1 mln (PY: -6.4), improving by more than EUR 5 mln.

Financial result

slightly worse than in previous year

The financial result 2004 amounting to EUR -3.3 mln was slightly worse than in the previous year (-2.8). It was negatively impacted by increases in interest expense, in impairment of financial assets and in other financial expenses, and positively impacted by a currency exchange rate gain and higher income from investments.

The result before taxes 2004 amounted to EUR -4.4 mln after EUR -9.2 mln in the previous year. Adjusted by impairments on goodwill and investments, the pretax result amounted to EUR -1.0 mln (PY: -7.5).

The aftertax result development was similar. On a purely operating base, the tax load was EUR 0.3 mln, resulting in an adjusted aftertax result amounting to EUR -1.3 mln (PY: -4.7).

Balance sheet relief concerning tax assets

To relieve the balance sheet, an impairment of tax assets in an amount of EUR 4.6 mln was booked. The main reason for this was the minimum taxation in Germany which extends the time for consumption of loss carryovers significantly. The amount of impairment represents those tax assets which are estimated to take more than five years for depreciation. The impairment will be written back during the next four to five fiscal years in the case of normal course of business and thus will relieve the aftertax result in these years accordingly.

This impairment increased the booked tax load for 2004 to EUR 4.8 mln (PY: positive tax effect EUR 2.9 mln), resulting in a net result amounting to EUR -9.2 mln (PY: -6.4) before and EUR -9.3 mln (PY: -6.3) after minority interest.

The undiluted result per share in 2004 amounted to EUR -0.84 (PY: -0.62). On a purely operating base, adjusted by impairments of goodwill, investments and tax assets, the undiluted result per share amounted to EUR -0.12 (PY: -0.43).

Expansion strategy until 2002 with high investments ...

The M+M group has invested heavily in the years since 1998. Investments were made first for international expansion, pushing M+M into the group of leading CAD vendors in Europe, and second, in the course of the Technology Offensive, balancing the product portfolio across trading products and M+M technology. The peak of investment activities was passed in the year 2000, when cash investments amounting to EUR 13.9 mln were made. In the two following years, cash investments totalled significantly lower: 2001 at EUR 5.8 mln and 2002 at EUR 6.9 mln.

... widely financed using equity and debt

The financing of this expansion was only in 2001 covered by the operating cashflow, in the other years financing was done first by use of equity and from 2000 onwards by use of bank credits available in sufficient volume and at favourable conditions. This expansion policy led to a non optimal balance sheet structure with an excess on the debt side.



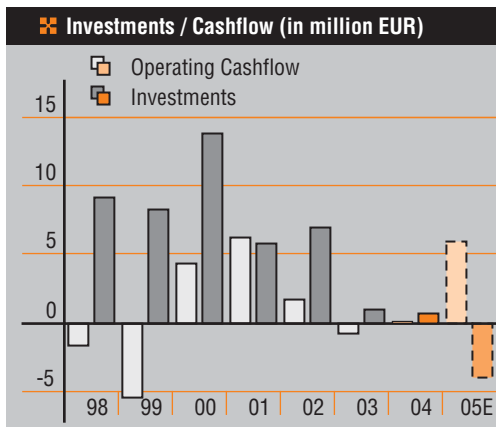

After significant investments until 2002 and following the two years of consolidation, 2003 and 2004, M+M will generate cash inflows both from operations and from the COMPASS disinvestment in 2005.

Net debt further reduced significantly

Net debt, defined as current plus non-current bank debt minus cash, could be reduced as of Dec 31, 2004 to EUR 25.4 mln, being EUR 5.9 mln below previous year's amount of EUR 31.3 mln. Compared with the historical high of EUR 37.2 mln reached at Sep 30, 2002, net debt was reduced by nearly 12 million Euro or 32%.

Only moderate investments since 2003

After completion of the technology offensive the investments were reduced to those amounts necessary for keeping the fixed assets on an actual status. These amounts were EUR 0.9 mln in 2003 and EUR 0.5 mln in 2004. Also for the years to come, only investments in this order of magnitude are necessary, because in the M+M business model the main future investment is in the area of software development, the expenses for which are not capitalized.

Total assets heavily decreased

Total assets in the group decreased heavily to EUR 69.1 mln (PY: 80.1 / -14%) and are significantly lower than in fiscal year 2000, before starting the technology offensive. The primary driver for this development apart from the balance sheet cleanup was a radical reduction of the value bound in inventories. These were driven down since the year 2000, when inventories amounted to EUR 19.1 mln, to a historical low of EUR 4.5 mln (PY: 5.1 / -13%) in 2004. Additionally, accounts receivable were reduced to EUR 25.0 mln (PY: 27.8 / -10%).

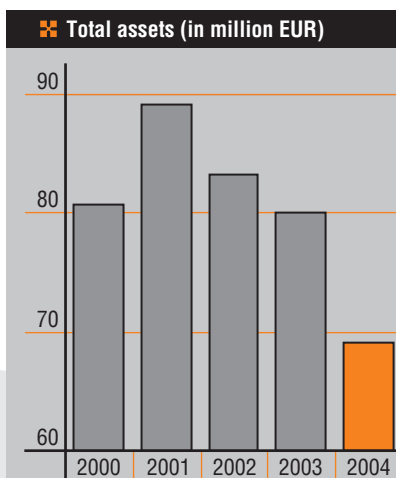
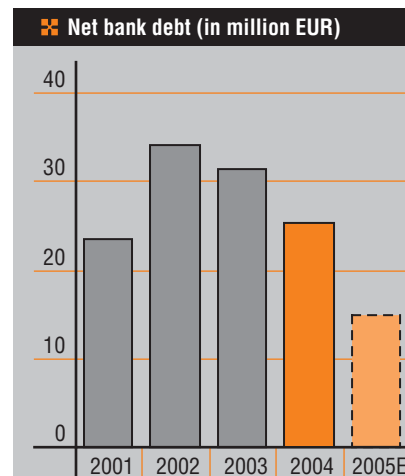

Convertible loan and capital increase

This reduction of bank debt mainly results from cash inflows totalling EUR 4.8 mln from the mid year offering of a convertible loan and a capital increase at the end of year.

Shareholders' equity according to IAS/IFRS in the group as of Dec 31, 2004, decreased through the balance sheet clean ups to EUR 8.7 mln (PY: 14.8), the capital ratio amounted to 12.6% (PY: 18.5%).

Shareholders' equity in the financial statements of the mother company M+M AG set up in accordance to German accounting standard HGB, which was also cleaned up, amounted to EUR 15.3 mln (PY: 25.4) as of Dec 31, 2004, with a capital ratio of 28.0% (PY: 38.1%).

Continuing strong focus on debt reduction

Altogether, the balance sheet structure is still not optimal, in spite of the partial repayment of bank debt. Therefore further lowering of bank debt remains the highest focus for the management board. Operating cashflow as well as the disinvestment of COMPASS will contribute to this. The target for the end of 2005 is a reduction of net bank debt to less than EUR 15 mln.

Risks

The operations and activities of the M+M group are subject to various risks. The risk management is controlled directly at board level by monitoring risk relevant parameters from the individual group segments and by comparison with the internal targets, to allow for a timely reaction in case of changes within the enterprise or in the enterprise's environment.

In detail, the following risk categories exist:

Credit risks:

Bad debt risks are counteracted with customer credit insurance, individual bad debt provisions, and streamlined receivables management.

Also favourable in this respect, is the fact that sales are divided among many individual customers each of which carries less than 3% of the total revenue.

Warehouse and transport risks:

These risks are generally covered by corresponding insurance contracts.

A risk of loss in value during warehousing can be considered virtually non-existent since the suppliers' software product contracts always comprise a price, update and stock rotation clause.

Sales and market risks:

As with every other supplier of standard software, M+M is subject to software market and product cycles, especially those of the CAD market. Such risks are generally counteracted, as far as possible, by the vertical and regional division of the M+M Group as well as by the spread across several product lines, but risk may not always be fully compensated by these actions.

Personnel risks:

As an enterprise in the software industry, M+M is, in principle, dependent on individuals with special skills. M+M's distinctive corporate culture, so far, has been instrumental in keeping employee turnover exceptionally low. The risk of dependence upon key top management people has been counteracted by appointing several individuals to the management board and by strengthening the secondary management level.

Supplier risks:

Concentration on the main suppliers Autodesk and PTC represent a certain risk through dependency on these suppliers' product development, market competence and operational policy. Due to the fact that the contracts are normally short term, there is also the risk of non prolongation by the suppliers.

Losses at subsidiaries and shareholdings:

In all shareholding or subsidiary relationships, it is recognised that there is a risk that, contrary to positive expectations, a negative development may occur possibly proceeding to total loss.

This would not only cause an appropriate depreciation of goodwill or investment value but also lead to a corresponding writedown of deferred tax assets in case of fully consolidated subsidiaries with loss carryovers.

Financing and liquidity risk:

As in any business model not exclusively financed by equity, there is a dependency risk for the debt financed part due to the refinancing capabilities of the financial market. This risk is counteracted by distribution of relatively many credit lines at several banks inside and outside Germany. It cannot be excluded, however, that the refinancing interest rate payable by M+M may develop negatively or the refinancing by debt may fail in parts or in total, which would cause serious problems for the liquidity and further development of the group.

In this respect, internal as well as external influences play a roll. Internal influences are mainly the earnings and financial status impacting the M+M market rating, as well as the management's ability in handling relationships with existing and potential creditors. External influences are for example the general interest rate level on the market, the credit policy of banks and other creditors, as well as the legal framework conditions like the Basel-II-Guidelines being intensively discussed. Also the present crisis in the German banking sector may have a negative impact on the financing abilities. The Management Board does not see a concrete danger for the M+M group due to the existing liquidity plan. Though the liquidity situation remains relatively tight as long as the free cashflow is directly used for repayment of credit lines, the Management Board is convinced that, considering the sale of COMPASS and the expected positive cashflow, liquidity can be driven to a comfortable level in the course of the year. The principle risk of liquidity bottlenecks, however, cannot be completely excluded.



Outlook

After completion of the operating turnaround and the balance sheet clean up carried out, M+M can look to the future more freely.

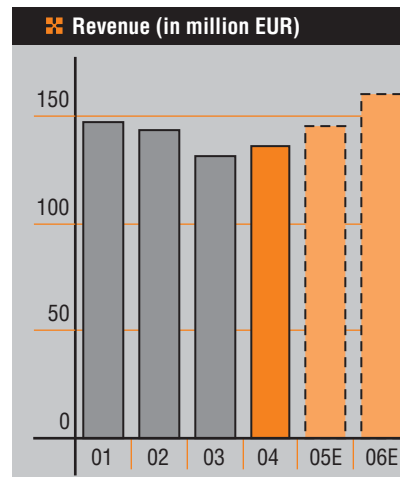

2005:

Moderate sales growth and earnings leap

For the current fiscal year 2005 the management is expecting moderate sales growth to approximately EUR 145 mln, representing - in spite of the COMPASS discontinuation - a growth rate around 7 percent.

For operating result EBITA a significant increase to approximately EUR 6 mln is expected due to further expense reduction. This would nearly reach the level of the record year 2001. The net result is then estimated to jump to a minimum EUR 6 mln or EUR 0.50 per share, to which operations and the net gain from the COMPASS sale will contribute half and half.

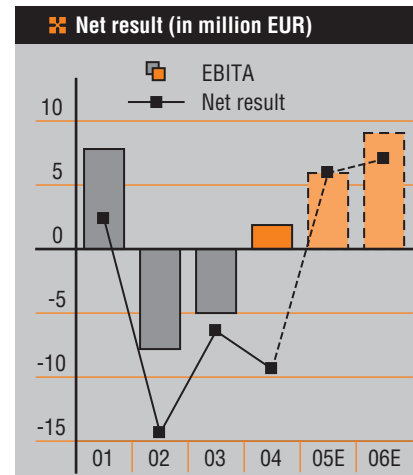

Resumption of dividend payment

In case of the achievement of the above targets, a small dividend payment in the order of magnitude of EUR 0.10 per share would be possible after three years of abstinence.

2006:

Further improvement of profitability

In the following fiscal year 2006, optimization of the operating margin will still remain the priority target in combination with cautious revenue growth. Along with a revenue target in the order of magnitude of EUR 160 mln, an operating income EBITA amounting to EUR 9 mln is estimated. The expected improvement in interest payments due to the bank debt reduction, combined with a low tax rate (use of loss carryovers), should result in a net profit in the order of magnitude of EUR 7 mln or EUR 0.58 per share, completely coming from normal operations. This would enable an accordingly higher dividend payment.

All estimates subject to error

All forward looking statements made herein are subject to market conditions occurring in line with estimations in the planning models set up by the management. Therefore no guarantee can be undertaken for meeting the estimates.

Thanks to employees and shareholders

The management team would like to take the opportunity to thank all employees for their enormous engagement during the past fiscal year, which was characterized by huge challenges for development and restructuring the M+M group and demanding the highest efforts from all people involved.

In addition, we would like to express our thanks to our shareholders for their loyalty towards Mensch und Maschine Software AG in turbulent times or for newly investing in the M+M share.

Wessling, March 2005
Mensch und Maschine Software AG
The Board of Management

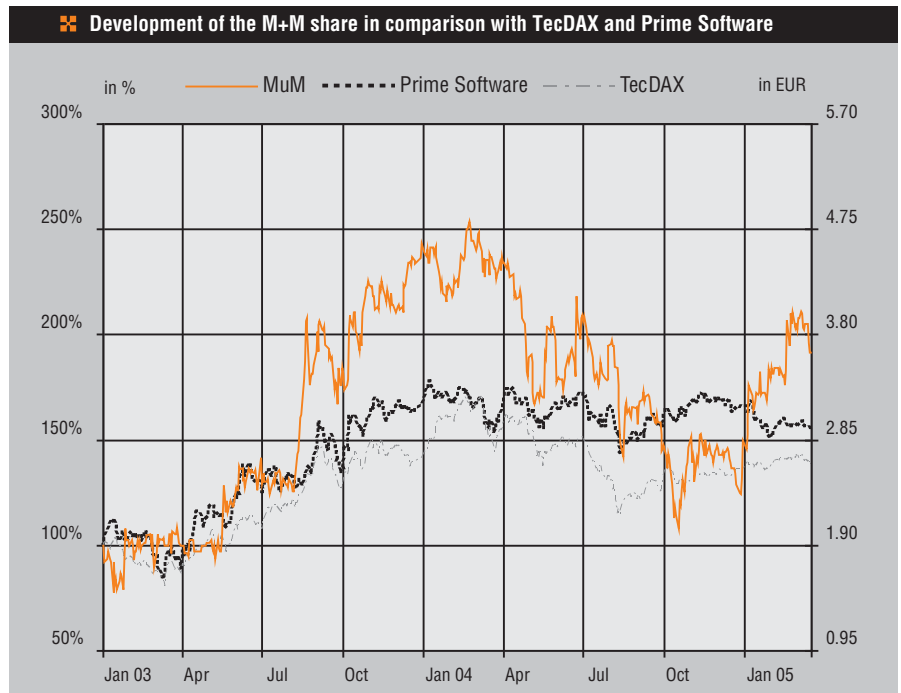

The M+M share has gained around 100% since the beginning of 2003, outperforming the comparative indexes TecDAX and Prime Software

❖ Statement of income						
Amounts in KEUR	Note*	2004		△%	2003	
Revenues	1	135,478	100%	+3.4%	131,018	100%
Cost of revenues	2	-92,836	-68.5%	+4.8%	-88,555	-67.6%
Gross margin		42,642	31.5%	+0.4%	42,463	32.4%
Selling and marketing expenses	3	-26,654	-19.7%	-6.6%	-28,530	-21.8%
General and administrative expenses	4	-9,106	-6.7%	-5.8%	-9,676	-7.4%
Research and development expenses	5	-7,595	-5.6%	-10%	-8,448	-6.4%
Other income	6	4,505	3.3%	+162%	1,719	1.3%
Other expenses	7	-1,907	-1.4%	-25%	-2,552	-1.9%
Operating result EBITA before amortization/impairment of goodwill		1,885	1.4%		-5,024	-3.8%
Amortization or impairment of goodwill	8	-3,000	-2.2%		-1,390	-1.1%
Operating result EBIT before interest and taxes		-1,115	-0.8%		-6,414	-4.9%
Financial result	9	-3,284	-2.4%		-2,809	-2.1%
Result before taxes		-4,399	-3.2%		-9,223	-7.0%
Taxes on income	10	-4,591	-3.4%		3,215	2.5%
Other taxes		-183	-0.1%		-345	-0.3%
Net result before minority interest		-9,173	-6.8%		-6,353	-4.8%
Minority interest		-85	-0.1%		36	
Net income / loss		-9,258	-6.8%		-6,317	-4.8%
Net income per share (basic)	11	-0.84			-0.62	
Net Income per share (diluted)		-0.83			-0.62	
Weighted average shares outstanding in million (basic)	11	10.972			10.232	
Weighted average shares outstanding in million (diluted)		11.757			10.652	

* see notes on pages 42 - 45

Balance sheet					
Amounts in KEUR	Note*	Dec 31, 2004	Δ%	Dec 31, 2003	
Cash and cash equivalents		1,118	-22%	1,435	
Trade accounts receivable	12	25,007	-10%	27,787	
Accounts receivable due from related parties		698	-27%	958	
Inventories	13	4,491	-13%	5,138	
Prepaid expenses and other current assets	14	2,051	+34%	1,527	
Total current assets		33,365	48.3%	36,845	46.0%
Property, plant and equipment		3,161	-12%	3,596	
Intangible assets		851	-14%	993	
Goodwill	15	20,889	-13%	23,889	
Investments in affiliated companies	16	1,754	+12%	1,561	
Other Investments	17	2,348	-16%	2,796	
Deferred taxes		6,727	-36%	10,459	
Total non current assets		35,730	51.7%	43,294	54.0%
Total assets		69,095	100%	80,139	100%
Short term debt and current portion of long term debt	18	25,006	-11%	28,030	
Trade accounts payable		22,451	+1%	22,251	
Accounts payable due to related parties		377	-9%	416	
Advance payments received		241	+73%	139	
Accrued expenses	19	3,405	+6%	3,201	
Deferred revenues		116	-80%	581	
Income tax payable		551	-2%	561	
Other current liabilities	20	2,318	-25%	3,102	
Total current liabilities		54,465	78.8%	58,281	72.7%
Long term debt, less current portion	21	1,482	-68%	4,678	
Convertible loan	22	1,793		0	
Deferred taxes		82	+20%	68	
Pension accruals	23	355	+29%	276	
Other accruals		153	-24%	202	
Other non current liabilities	24	1,500	+5%	1,429	
Total non current liabilities		5,365	7.8%	6,653	8.3%
Minority interest		526	0.8%	441	0.5%
Share capital	25	12,030	+72%	7,012	
Capital reserve	26	3,054	-90%	29,241	
Other reserves		221		221	
Retained earnings / accumulated deficit		-6,672	-69%	-21,650	
Currency conversion		106		-60	
Total shareholders' equity		8,739	12.6%	14,764	18.5%
Total liabilities and shareholders' equity		69,095	100%	80,139	100%

* see notes on pages 46 - 51

 Statement of cash flows			
Amounts in KEUR	Note*	2004	2003
Net result		-9,258	-6,317
Depreciation and amortization		4,804	3,317
Other non cash income / expenses		1,732	-3,615
Increase/decrease in provisions and accruals		234	-423
Losses/gains on the disposal of fixed assets		-160	-143
Change in net working capital		2,807	6,392
Net cash provided by operating activities	27	159	-789
Acquisition of subsidiaries, net of cash acquired		0	-107
Purchase of property, plant and equipment		-470	-819
Net cash used in investing activities		-470	-926
Proceeds from issuance of share capital		2,863	3,295
Proceeds from issuance of convertible loan after transaction costs		1,892	0
Proceeds from short or long term borrowings		-4,778	-1,384
Net cash provided by financing activities		-23	1,911
Net effect of currency translation in cash and cash equivalents		17	-10
Net increase / decrease in cash and cash equivalents		-317	186
Cash and cash equivalents at beginning of period		1,435	1,249
Cash and cash equivalents at end of period		1,118	1,435

* see notes on page 51

Development of shareholders' equity						
Amounts In KEUR	Subscribed Capital	Capital Reserve	Other Reserves	Profit/Loss	Currency exchange	Total Equity
As of Jan 1, 2003	6,445	26,513	221	-15,333	-86	17,760
Capital increase	567	2,874				3,441
Costs of capital increase		-142				-142
Proceeds from profit sharing rights		-4				-4
Net result				-6,317		-6,317
Currency conversions					26	26
As of Dec 31, 2003	7,012	29,241	221	-21,650	-60	14,764
Conversion to 1 EUR par share value	3,960	-3,960				0
Capital increase	1,058	1,852				2,910
Costs of capital increase		-47				-47
Convertible loan		211				211
Costs of convertible loan		-7				-7
Net result				-9,258		-9,258
Netting of capital reserve		-24,236		24,236		0
Currency conversions					166	166
As of Dec 31, 2004	12,030	3,054	221	-6,672	106	8,739

Segment reporting

The consolidated financial statement comprises a segment report according to IAS 14.

There were no material revenues between the segments. Due to non-materiality the total amount of depreciation on segment assets in accordance with IAS 14.58 is not disclosed.

Primary segmentation

The primary segmentation differentiates M+M technology from trading products. The first category contains all proprietary products developed within the M+M group or exclusively licenced by M+M as well as service revenues, the second category contains all trading products sold by the M+M group.

Geographical segmentation

The secondary segment is geographic and distinguishes product and service revenues by the group companies inside and outside Germany.

Within the segment reporting, expenses are reported separately for the segments, allowing for a segment specific report of gross profit as well as operating income before amortization of goodwill. Additionally, the distribution of impairments, income from affiliated companies, fixed assets, investments of the fiscal year and liabilities are separately reported for the segments.



Primary segmentation

Amounts in KEUR	2004				2003			
	M+M technology		Trading products		M+M technology		Trading products	
Revenues	26,733	20%	108,745	80%	25,065	19%	105,953	81%
Cost of revenues	-4,308	5%	-88,528	95%	-3,863	4%	-84,692	96%
Gross margin	22,425	53%	20,217	47%	21,202	50%	21,261	50%
Selling and marketing expenses	-9,631	36%	-17,023	64%	-9,205	32%	-19,325	68%
General and administrative expenses	-3,095	34%	-6,011	66%	-3,770	39%	-5,906	61%
Research and development expenses	-7,595	100%	0	0%	-8,448	100%	0	0%
Other income	2,063	46%	2,442	54%	660	38%	1,059	62%
Other expenses	-1,011	53%	-896	47%	-1,455	57%	-1,097	43%
Operating result EBITA before amortization/impairment of goodwill	3,156		-1,271		-837		-4,187	
Impairment of assets	-3,440	100%	0	0%	-285	100%	0	0%
Income from affiliated companies	193	100%	0	0%	180	100%	0	0%
Fixed assets	14,278	49%	14,725	51%	18,241	56%	14,594	44%
thereof affiliated companies	1,754	100%	0	0%	1,561	100%	0	0%
Investments	316	67%	154	33%	546	59%	380	41%
Liabilities	24,415	41%	35,415	59%	27,088	42%	37,847	58%

Secondary segmentation

Amounts in KEUR	2004				2003			
	Germany		International		Germany		International	
Revenues	41,530	31%	93,948	69%	48,134	37%	82,884	63%
Cost of revenues	-21,283	23%	-71,553	77%	-26,182	30%	-62,373	70%
Gross margin	20,247	47%	22,395	53%	21,952	52%	20,511	48%
Selling and marketing expenses	-12,326	46%	-14,328	54%	-14,954	52%	-13,576	48%
General and administrative expenses	-3,628	40%	-5,478	60%	-4,536	47%	-5,140	53%
Research and development expenses	-7,595	100%	0	0%	-8,448	100%	0	0%
Other income	3,996	89%	509	11%	1,248	73%	471	27%
Other expenses	-896	47%	-1,011	53%	-1,327	52%	-1,225	48%
Operating result EBITA before amortization/impairment of goodwill	-202		2,087		-6,065		1,041	
Impairment of assets	-3,440	100%	0	0%	-285	100%	0	0%
Income from affiliated companies	0	0%	193	100%	0	0%	180	100%
Fixed assets	18,459	64%	10,544	36%	21,276	65%	11,559	35%
thereof affiliated companies	0	0%	1,754	100%	0	0%	1,561	100%
Investments	408	87%	62	13%	735	79%	191	21%
Liabilities	36,903	62%	22,927	38%	40,005	62%	24,930	38%

GIS in practice

gardening and landscaping

Project: Water development plan for the river Neckar in the Rottweil area

Customer: Siegmund+partner, freelance landscape designer BDLA, Schoenberg, Germany

For many years, Siegmund+partner have been working successfully with intergral solutions from DATAflor, a M+M group member. By fully integrating the software for planning and tendering, all functions and processes run smoothly, giving Siegmund+partner a competitive advantage.

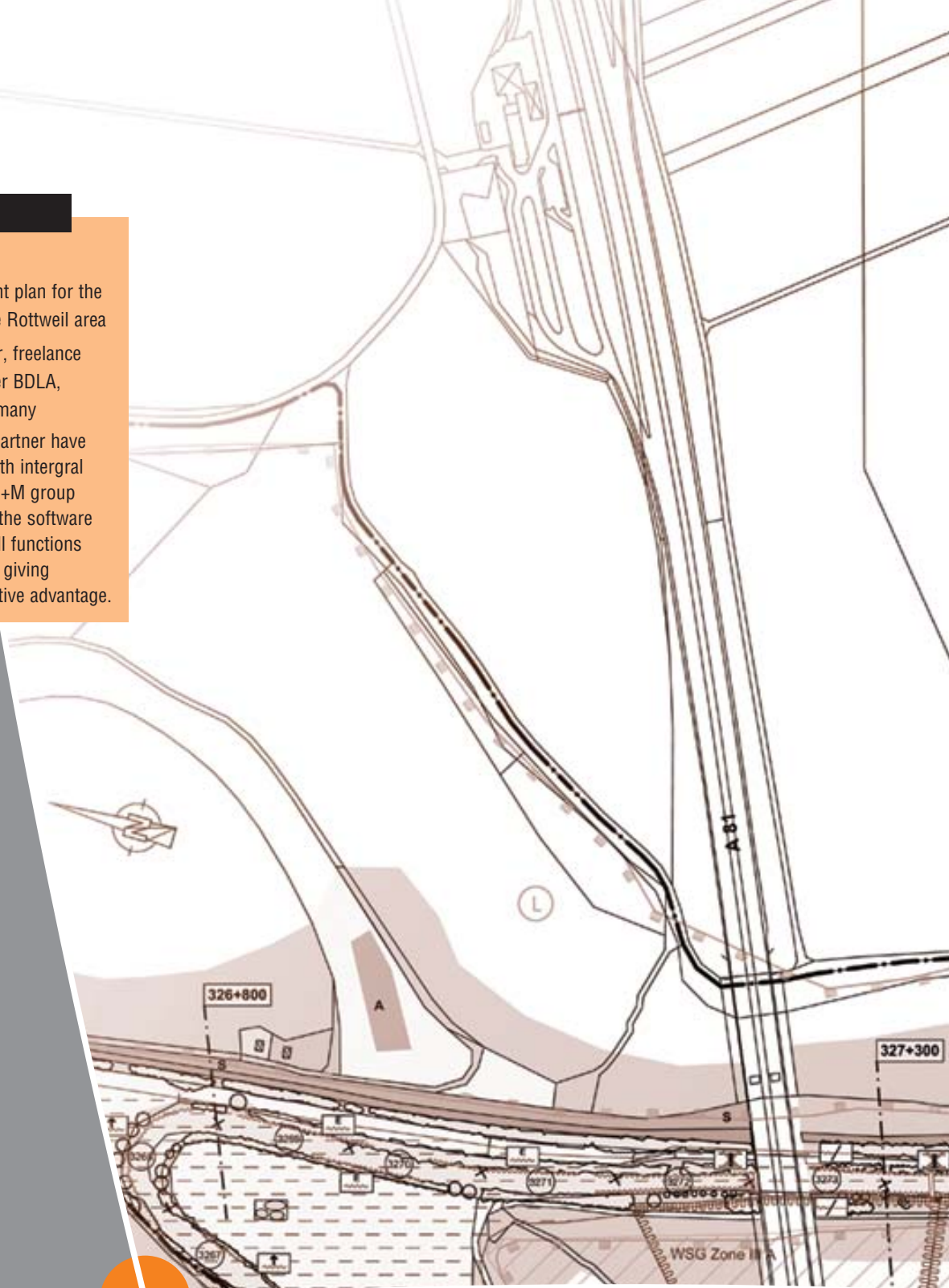

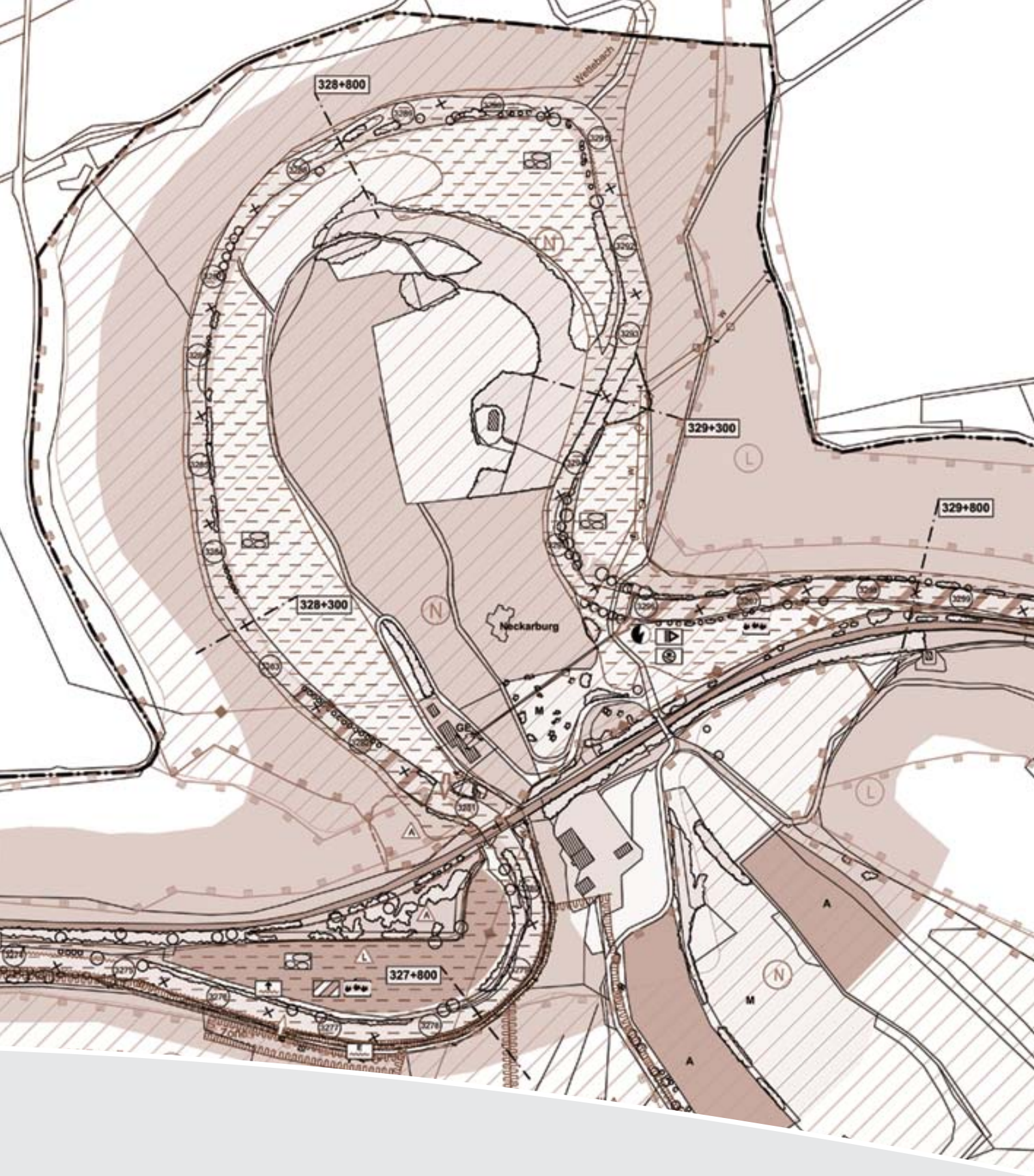

Notes

General remarks

Basis of the group financial

The consolidated financial statement of Mensch und Maschine Software AG, Wessling, Germany has been drawn up in compliance with International Financial Reporting Standards (IFRS) according to the specifications as defined in the currently valid guidelines of the International Accounting Standards Board (IASB). All International Financial Reporting Standards (IFRS) and International Accounting Standards (IAS) in effect at the closing date have been considered. Changes of standards due to the Improvement Projects of the IASB (including the changes of IAS 32 and IAS 39) were not considered.

Of the IFRS standards which have been adopted in 2004,

IFRS 2: Share based Payments,

IFRS 3: Business Combinations,

IFRS 4: Insurance Contracts,

IFRS 5: Non current Assets held for Sale and Discontinued Operations,

IFRS 6: Exploration for and Evaluation of Mineral Resources

only IFRS 3: Business Combinations has been adopted early according to IFRS 3.85 in combination with the revised IAS 36: Impairment test and IAS 38: Intangible assets. Regarding the details we refer to "Principles of consolidation".

In connection with drawing up the group financial statement according to the International Financial Reporting Standards (IFRS), no group financial statement according to the German accounting standards (HGB) was drawn up in accordance to §292a HGB.

Valuation methods and accounting policies applied

Consolidated companies and closing date

In addition to the parent company, the consolidated financial statement comprises all directly and indirectly owned domestic and international subsidiaries, at which M+M AG has directly or indirectly the majority of the voting rights or the control of the economic power, which are included in accordance with the principles of full consolidation.

In addition to the parent company, the companies listed opposite were fully consolidated in the group financial statement of December 31, 2004.

Balance sheet closing date for the subsidiaries included in the group consolidated financial statement is December 31.

In the reporting period AIM systems GmbH has been renamed to COMPASS systems GmbH.

The financial statements of all group companies were drawn up on the basis of common accounting principles. As far as there is an obligation to examine, they are audited by independent auditors and endorsed by an unqualified auditing opinion.

❖ M+M group consolidated companies

Mensch und Maschine Systemhaus GmbH, Wessling	100%
Mensch und Maschine Akademie GmbH, Bad Boll, Germany	100%
Mensch und Maschine Software AG, Riehen (Basel), Switzerland	100%
Mensch und Maschine Software Ges.m.b.H., Salzburg, Austria	100%
Man and Machine S.a.r.l., Bagnolet (Paris), France	100%
Man and Machine Software s.r.l., Vimercate (Mailand), Italy	100%
Man and Machine Software Sp.ZO.O., Lodz, Poland	100%
Man and Machine UK Ltd., Thame, UK	100%
Man and Machine AB, Sundbyberg (Stockholm), Sweden	100%
Man and Machine Benelux NV, Ternat (Brüssel), Belgium	100%
EUKLID Software GmbH, Wessling, Germany	100%
DATAflor Software Aktiengesellschaft, Goettingen, Germany and 100% shareholdings: DATAflor EDV fuer die gruene Branche GmbH, Goettingen, Germany DATAflor Vertriebs GmbH, Grossbeeren, Germany DATAline Service und Support GmbH, Goettingen, Germany	61.5%
Compass systems GmbH, Karlsfeld near Munich, Germany	50.1%
Elektro-CAE-Software GmbH (ECS), Donzdorf, Germany	60%
OPEN MIND Technologies AG, Unterfoehring, Germany and 100% shareholdings: OPEN MIND Software Technologies USA Inc., Southfield/Michigan, USA OPEN MIND Software Technologies PTE Ltd., Singapore OPEN MIND Software Technologies Italia s.r.l., Rho (Mailand), Italy OPEN MIND Software Technologies S.a.r.l., Le Bourget du Lac Cedex, France OPEN MIND Software Technologies UK Limited, Thame, UK	100%

Principles of consolidation

The consolidated financial statements include the business of all majority-owned subsidiaries, of which MuM has control according to IAS 27.6, mainly because of a share ownership of more than 50 percent.

The capital consolidation pursuant to IFRS 3.14 is performed using the benchmark method, by offsetting the book values of the shares with the pro rata equity of the subsidiaries included in the group consolidated financial statement at the date of acquisition or as a first-time consolidation. Date of acquisition is the date at which M+M AG takes the effective control over the company. Normally, this is the time at which the majority of the voting rights are acquired.

The differences arising from the consolidation of capital, to the extent that they are assets, are indicated as goodwill under non-current assets. There were no negative differences in the M+M group.

Minority shares are valued at closing time with their share in shareholders equity respective earnings of the year of the particular subsidiary. For M+M rule IAS 27.27 is applied saying that negative minority shares have to be settled with shareholders equity

and that no minority shares debit or credit shall be applied to group income statement as long as no positive minority share results which, according to IAS 27.26, has to be shown separated from liabilities and shareholders equity in the group balance sheet.

Receivables, reserves, liabilities, accruals and deferrals resulting from intra-group transactions are mutually offset. Differences from the consolidation of debt are treated with effect on earnings. Contingent liabilities were consolidated to the required extent. Interim profits and losses resulting from intra-group supply and service trading were likewise eliminated as were investment returns from companies included in the consolidation. Intra-group sales revenues as well as other intra-group earnings were offset by the appropriate expenditures.

With regard to the consolidation measures affecting results, tax deferrals pursuant to IAS 12 were carried out to the extent that the deviation in tax expenditure would conceivably be balanced in future fiscal years. Deferred taxes were not regarded in cases of semi-permanent differences (goodwill). The total amount of deferred taxes from the individual and consolidated financial statements is included in the item income taxes in the statement of income.



Estimations and assumptions

Drawing up the group financial statement required estimations and assumptions which can impact the amounts of assets, liabilities and financial obligations at closing date as well as returns and expenses in the fiscal year under review. The actual amounts can differ from these estimations and assumptions.

Currency conversion

The annual financial statements of the group's international subsidiaries were converted into EUR in accordance with the principle of functional currency in compliance with IAS 21. This refers to the respective national currency for all companies since these international companies are financially, economically and organizationally independent with respect to their operations.

Accordingly, equity was converted at the historical exchange rate, the other balance sheet items were converted at the exchange rate on closing date, and income and expenditures as well as year-end results were converted using a mean exchange rate for the year. In compliance with IAS 21, differences arising from currency conversion of both capital consolidation and transfer of the annual earnings to the balance sheet at the mean annual exchange rate were treated as having no effect on earnings and are included within equity.

Structure of statement of income and balance sheet

In keeping with the international practice of consolidated financial statements, the report begins with the statement of income (profit and loss), itemized according to the cost-of-sales method. In accordance with IAS 1, the balance sheet is apportioned into current and non-current assets and into current and non-current liabilities. To improve the clarity in the profit and loss statement some positions of the financial result are summarized and described in the Notes. The restructuring expenditures were assigned to the other expenditures. To guarantee the comparability, the previous year was adapted accordingly.

Accounting and valuation methods

Cash and cash equivalents

M+M shows credit balances at banks under cash and cash equivalents. Foreign currency credit balances are converted by exchange rate at closing date.

Property, plant and equipment

Property, plant and equipment are reported at cost of acquisition less regular depreciation. These assets are depreciated over the useful economic life of 3 to 10 years.

Low value items

Low value items with a acquisition value of less than EUR 400 are fully written off in the year of purchase.

Intangible assets

Intangible assets are reported at cost of acquisition less regular depreciation. These assets are depreciated over the useful economic life of 3 to 5 years.

Intangible assets, acquired in the context of a business combination, are capitalized at fair value as at the date of acquisition. Following initial recognition, the cost model is applied to the class of intangible assets. The useful lives of these intangible assets are assessed to be either finite or indefinite. Where amortisation is charged on assets with finite lives, this expense is taken to the income statement through various line items.

Intangible assets, excluding development costs, created within the business are not capitalised and expenditure is charged against profits in the year in which the expenditure is incurred.

Intangible assets are tested for impairment annually either individually or at the cash generating unit level. Useful lives are also examined on an annual basis and adjustments, where applicable, are made.

Research costs are expensed as incurred. Development expenditure incurred on an individual project is carried forward when its future recoverability can reasonably be regarded as assured.

Goodwill and impairment

Goodwill on acquisition is initially measured at cost, being the excess of the cost of the business combination over the acquirer's interest in the net fair value of the identifiable assets, liabilities and contingent liabilities. Following initial recognition, goodwill is measured at cost less any accumulated impairment losses.

On March 31, 2004, the International Accounting Standards Board (IASB) issued IFRS 3 Business Combinations as well as IAS 36 Impairment of Assets (revised 2004) and IAS 38 Intangible Assets (revised 2004). IFRS 3 is part of a comprehensive revision of the accounting for business combinations. It replaces the past standard IAS 22. IFRS 3 applies to accounting for business combinations for which the agreement date is on or after March 31, 2004. Thus all business combinations are to be balanced according to the purchase method. Furthermore the regular amortisation of goodwill is now forbidden.

The early adoption of IFRS 3 (business combinations) has resulted in the ceasing of annual goodwill amortisation after January 1, 2004 and to test for impairment annually at the cash generating unit level according to IAS 36 (revised 2004).

In the context of the impairment test the recoverable amount of the cash generating units is determined by the current value less sales costs or the value in use. The individual subsidiaries of M+M were defined as cash generating units.

The current value reflects the best estimation of the amount, for which an independent third party would acquire the cash generating units as of balance-sheet date; Sale costs are taken off.

The value in use is determined on the basis of DCF methods. To calculate this, cash flow projections are based on financial budgets approved by senior management covering a three-year period. This planning is based on experiences from the past as well as on expectations over the future market development.

The growth rate applied to cash flow projections is between 5% and 7.5% for gross margin and between 2.5% and 5% for expenses.

The discount rate is determined on the basis of market data and considers credit and market risks. For the cash generating units it amounts to 9.95%.

Where the recoverable amount of the cash generating unit is less than the carrying amount, an impairment loss is recognized.

Other Investments

Financial assets include shareholdings in other companies. The reported shareholdings are exclusively shareholdings without substantial influence. Consequently, it is not necessary to value them pursuant to IAS 28 (Accounting for Investment in Associates). Pursuant to IAS 27.24, shares in companies that do not fall in the category group companies and associated companies, are to be valued pursuant to IAS 39 (Financial Instruments). In accordance with IAS 39.66, all shareholdings are reported at cost of acquisition the first time they are recorded, corresponding to the fair value of the stated asset. This is the equivalent of cash or cash equivalents. The shareholdings reported within the M+M Group are financial assets available-for-sale pursuant to IAS 39.10, as none of the other categories under IAS 39 apply. As the financial assets do not have a listed market price on an active market and it is therefore impossible to reliably calculate a fair value, the subsequent valuation is also at cost of acquisition (IAS 39.73), whereby all shareholdings are checked for signs of depreciation (Impairment Test).

In general, the shareholdings are checked for depreciation by means of valuations which are taken as a basis when the shares in shareholdings are transferred. The transactions invoked for the purposes of valuation take place between third parties outside the Group. In addition, DCF methods and industry-specific multipliers are applied for the impairment testing. Actually twice the sustained annual gross margin is taken as the maximum book value of an investment not causing an impairment.

Inventory

The valuation of the inventory depends on the regulations of IAS 2. This position contains mainly finished goods which are capitalized at cost. If necessary a inventory valuation adjustment is made due to a reduced usability. All recognizable risks are considered by appropriate adjustments.

Financial Instruments

Financial instruments entail contractual claims on financial assets. According to IAS 32, financial instruments also include primary instruments, such as trade accounts receivable and payable, investments and financial liabilities.

According to IAS 39, financial instruments are categorized as:

- extended loans and receivables
- held for trading
- available for sale
- held to maturity

Extended loans and receivables are stated at cost less accumulated depreciation and any impairment in value.

Investments classified as held for trading and available-for-sale, are measured at fair value and accounted in consideration of fluctuations between the trading and the settlement day. Gains or losses on these investments are recognized in income.

Investments classified as held-to-maturity, are measured at cost less any impairment in value, and accounted for in consideration of fluctuations between the trading and the settlements day.

The liquid assets, trade receivables and payables have such short terms that there is no significant discrepancy between their fair values and carrying amount.

Credit risk arises from the possibility of asset impairment occurring because counterparties cannot meet their obligations in transactions involving financial instruments. Since M+M do not conclude master netting arrangements with our customers, the total of the amounts recognized in assets represent the maximum exposure to credit risk.

Currency risk is the potential decline in value of financial instruments due to exchange rate fluctuations. Exposure to currency risk arises mainly when receivables and payables are dominated in a currency other than the companies' local currencies. Such risks may be naturally hedged due to receivables and payables in the same currency.

Interest rate risks apply mainly to receivables and payables with maturities of over one year. Items with such long maturities are not of material significance on the operating side. Investment and financial obligations are not hedged due to fixed interest rates.

Derivative financial instruments are not used in the M+M group.

Shares in affiliated companies

Participations where M+M AG exercises a relevant influence, usually due to an investment holding between 20 and 50 per cent, are accounted at equity according to IAS 28. With the equity method no assets and liabilities nor proceeds and expenditures are consolidated, but the historical acquisition costs are adjusted annually by the amount of equity change, which corresponds to the capital share of M+M AG. According to IFRS 3, the linear goodwill amortization has ceased.

During the first at equity incorporation of participation a difference from the initial consolidation is treated according to the principles of a full consolidation.

C-Plan AG, Muri near Bern, Switzerland, in which the M+M AG is holding 20 per cent investment, has been included at equity in the consolidated financial statements.

Deferred tax assets and liabilities

For the deferral of deferred taxes, M+M uses the balance-oriented temporary concept according to IAS 12. Therefore each balance and valuation discrepancy between IFRS and the tax balance is included in the deferral, if the difference dissolves in the lapse of time and has an effect on the taxable base. Additionally, deferred tax assets are capitalized on tax loss carry forwards according to IAS 12.34 if they can offset with probable future fiscal profits. This assessment is reviewed annually.

Borrowing costs

In accordance with IAS 23.10, borrowing costs are exclusively charged to expenditure.

Equity costs

According to SIC-17 the costs for the capital increase are offset with the additional paid in capital.

Accruals

Pursuant to IAS 37.36, accruals are to be reported at the amount resulting from the best estimate of the financial outflow required to meet current obligations as at the balance sheet date. The value stated for other accruals takes into account all identifiable risks based on past experience and where the scope and maturity is uncertain.

Pension accruals

The pension accruals essentially exist at the parent company and refer to a defined benefit plan for the management board. The pension commitment contains a retirement pay, a widow's pension as well as a disability pension. In the case of pension the payments are made monthly in advance.

Other assets and liabilities

For all identifiable risks of other assets, appropriate allowances are taken.

Liabilities are valued at their repayment value.

Foreign currency receivables and liabilities

In the individual financial statements, receivables and liabilities are translated at the rate on the balance sheet date. Profits and losses from the translation of foreign currency receivables and liabilities are reported in the Statement of Income under other income and expenses. As the income and expenses are not substantial, there are no notes relating to this position.

Principles of revenue recognition

In the M+M group, recognition of revenue occurs at that time when the risk passes to the customer. For service revenues the percentage-of-completion method is applied if the prerequisites of IAS 18.21 in connection with IAS 11 are met. The work in progress is determined on the basis of the already furnished project hours in comparison to the entire project volume.

Business combinations

IFRS 3 defines company acquisitions if one enterprise, the acquirer, obtaining control over the net assets and operations of another enterprise, the acquiree, whereby control presents the opportunity to govern the financial and business policies of a company so as to obtain benefits from its activities. In the reporting period no acquisitions occurred.

Stock option plans

According to IFRS 2 (Share-based Payments) share-based remuneration for employees granted after November 7, 2002 that had not vested on or before December 31, 2004, has to be accounted for as personnel expenditure for accounting years beginning on or after January 1, 2005. The cost of equity-settled transactions with employees is measured by reference to the fair value at the date at which they are granted. Therefore equity-settled transactions occur, when employees receive remuneration in the form of share-based payment transactions, whereby employees render services in exchange for shares or rights over shares. Since it is not possible to measure job performance at fair value, the fair value of the granted shares are used. Thus the costs of this remuneration system are measured by reference to the fair value at the date at which they are granted. The cost of equity-settled transactions is recognized, together with a corresponding increase in equity, over the year in which the performance conditions are fulfilled, ending on the date on which the relevant employees become fully entitled to the award ('vesting date').

IFRS 2 has to be applied for accounting years beginning on or after January 1, 2005. So Mensch und Maschine AG has not adopted this standard in the fiscal year 2004.



Mensch und Maschine are offering its members of the Board of Directors and other employees stock options in the form of an option plan, relaunched each year. The subscription price per share is the average closing price of the M+M share on the Frankfurt stock exchange on the first 30 trading days after the Annual Shareholders Meeting. The earliest the subscription right can be exercised is after the waiting period has expired. The waiting period amounts to 2 or 4 years after the stock option offer. The subscription right continues to exist four years after the waiting period has expired. The subscription right can only be exercised in certain exercise periods. For options issued after 1999, it can only be exercised if the stock market price of the M+M share is at least 15% above the strike price in the last

10 consecutive trading days before the respective exercise period. Before 1999, convertible profit-sharing rights ("Wandelgenussrechte") were issued as there was no legal possibility for genuine options at that time.

The options are converted by means of a capital increase from the contingent capital, so the conversion price thus leads to an injection of capital on the one hand and a corresponding increase in the number of shares on the other. In the last two lines of the table on the next page, the respective injection of capital for each issue year and overall is listed. The upper line only shows options exercisable as at December 31, 2004, and the lower line reports all outstanding options.

If all 436,346 exercisable options were converted, this would lead to an injection of capital amounting to KEUR 4,962. In terms of the number of shares as at December 31, 2004 (12,300,000) and the equity as at December 31, 2004 of KEUR 8,739, this would correspond to 3.63% growth in the number of shares and a 56.8% increase in the equity. In terms of the total number of exercisable stock options (436,346) plus those not yet exercisable (365,326), that means 801,672 outstanding options and an associated injection of capital amounting to KEUR 6,517, the following values are derived: number of shares +6.66% and capital growth +74.57%.

❖ Development of stock option rights								
Year of issue *		1998	1999	2000	2001	2002	2003	Total 98-03
Strike price	EUR	16.95	15.00	12.47	6.85	6.21	2.45	
Total number granted		232,400	181,800	176,600	226,296	249,268	241,108	1,307,472
as of Dec 31, 2004	exercised	1,200	-----	-----	-----	-----	-----	1,200
	expired	187,000	61,400	68,800	85,196	62,476	39,728	504,600
	exercisable	44,200	120,400	107,800	70,550	93,396	-----	436,346
	not yet exercisable total	-----	-----	-----	70,550	93,396	201,380	365,326
	exercisable as of							
	2005	-----	-----	-----	70,550	-----	100,690	171,240
	2006	-----	-----	-----	-----	93,396	-----	93,396
	2007	-----	-----	-----	-----	-----	100,690	100,690
Capital increase in KEUR for								
	Exercisable options only	749	1,806	1,344	483	580	0	4,962
	All options outstanding	749	1,806	1,344	966	1,159	493	6,517

* in 2004 no options were issued

Related Parties

In the course of our operating business we source and sell materials, inventories and services from and to a large number of business partners. These include companies with which members of the management board of M+M AG are associated. Werner Schwenkert is also chief operating officer of the M+M customer Follow Me GmbH.

Transactions with these companies are carried out on an arm's length basis. Business with such companies was not material from the viewpoint of M+M AG. The M+M AG was not a party to any transaction of an unusual nature or structure that was material to us or to companies or persons closely associated with us, nor does it intend to be party to such transactions in the future.

M+M's CEO and principal shareholder Adi Drotleff subscribed convertible loans amounting to KEUR 824, and granted M+M an interest free shareholder loan amounting to KEUR 1,500.

Notes to the statement of income

1. Revenues

This position contains trade sales amounting to KEUR 134,073 (PY: 128,740) and sales of business services amounting to KEUR 1,405 (PY: 2,278).

2. Cost of revenues

This position contains predominantly purchases of standard software products. Raw materials and external services play a very subordinate role.

3. Selling and marketing expenses

This position contains personnel expenses amounting to KEUR 13,843 (PY: 14,007), other operating expenses amounting to KEUR 12,023 (PY: 13,689), and depreciation amounting to KEUR 788 (PY: 834).

4. General and administrative expenses

This position contains personnel expenses amounting to KEUR 3,038 (PY: 4,481), other operating expenses amounting to KEUR 5,821 (PY: 4,719), and depreciation amounting to KEUR 246 (PY: 476).

5. Research and development expenses

This position contains personnel expenses amounting to KEUR 5,870 (PY: 5,705), other operating expenses amounting to KEUR 1,395 (PY: 2,412), and depreciation amounting to KEUR 330 (PY: 331).

6. Other income

Other income contains the profit from the sale of a product line of the Euklid amounting to TEUR 1,500, the profit from the partly waiver of a bank loan of TEUR 1,441, returns from private use of cars and telephones in the amount of KEUR 499 (PY: 528), rents received amounting to KEUR 169 (PY: 308) and other income amounting to KEUR 896 (PY: 883).

7. Other expenses

This position mainly implies restructuring costs amounting to KEUR 971 (PY: 2,036) and consulting costs amounting to KEUR 936 (PY: 132). In the prior year, it also contains bad debt expenses unrelated to the accounting period amounting to KEUR 384. In the annual report 2003, restructuring expenses of KEUR 2,036 and consulting expenses regarding the restructuring of KEUR 132 are shown in a separate line.

8. Impairment of goodwill

The impairment amounting to KEUR 3,000 applies to the goodwill of Euklid GmbH. In the financial year a product line not substantial for the M+M group was sold. The proceeds on disposal are contained in the other income. Determined by the sale, the future cash flow surplus is reduced, whereby the recoverable amount falls under the book value of Euklid (cash generating unit).

9. Financial result

	2004	2003
Interest income	78	54
Interest expense	-2,705	-2,509
Income from affiliated companies	193	180
Income from other investments and participations	110	77
Depreciation on financial assets	-440	-285
Foreign currency exchange gains / losses	201	-326
Other financial expenses	-721	0
Financial result	-3,284	-2,809

C-Plan AG, Muri near Bern, Switzerland, is included at equity in the consolidated financial statements. For 2004 the increase of the net book value of C-Plan AG amounts to KEUR 193 (PY: 180).

The depreciation of financial assets contains an extraordinary depreciation on the net book value of the shareholding in CYCO BV, Netherlands amounting to KEUR 440 (PY: 285).

The other financial expenditures essentially contain bank charges amounting to KEUR 350, costs of factoring amounting to KEUR 235 and costs of the convertible loan amounting to KEUR 105.

10. Taxes on income

This item encompasses tax payments amounting to KEUR 845 (PY: 400), a reduction amounting to KEUR 3,732 (PY: a surplus of 3,548) from further development and revaluation of tax assets in accordance with IAS 12, as well as a reduction of KEUR 14 (PY: a surplus of KEUR 67) from deferred taxes liabilities.

The deferred tax assets are mainly based on realizable tax loss carry forwards with an amount of KEUR 5,927 (PY: 9,136). The realization of the tax loss carry forward has been proved by planning forecasts and flexible tax models of optimization. Hereby only those tax loss carry forwards were activated, which can presumably be used within the following five years.

For fiscal years beginning in 2004, only gains amounting to KEUR 1,000 can be offset without a limit on taxable gains in Germany. Additional annual net profits can only be reduced by 60% with tax loss carry forwards.

At the moment there are no time restrictions for the utilization of the tax assets in the M+M group.

The temporary differences include deferred tax assets amounting to KEUR 800 (PY: 1,324) resulting from different valuations of intangible assets, as well as deferred tax liabilities amounting to KEUR 82 (PY: 68). The changes have been booked as tax expenditure or proceeds.

The transition between the expected taxes and the actual tax proceeds are explained by the following reconciliation:

✘ Tax reconciliation		
Amounts in KEUR	2004	2003
Result before income tax	-4,399	-9,223
Legal tax rate	37%	37%
Expected tax proceeds	1,628	3,413
Tax rate variances		
Foreign tax rate differential	-315	-274
Deviation of the taxable base		
Non deductible expenses	-113	-108
Tax free income from investments	71	67
Depreciation of a non taxable book value	-163	0
Amortization of goodwill	-1,110	-514
Taxable depreciation of intangible assets	459	459
Reversal of tax effects	0	296
Impairment of assets	0	-105
Valuation of deferred tax assets		
Non execution of deferred tax assets	-4,574	-285
Belated execution of deferred tax assets	0	518
Other	-474	-251
Actual tax load (PY: tax proceeds)	-4,590	3,215
Effective tax rate in %	-104.4%	34.9%

11. Calculation of shares outstanding and earnings per share

In accordance with IAS 33, a weighted average was calculated for shares outstanding. The diluted number of shares does not only include the original subscribed capital shares, but also all option rights from the employee option program which were exercisable at the statement closing date, but which had not yet been exercised.

For the purpose of calculating diluted earnings per share, the profit and loss attributable to ordinary equity holders and the weighted average number of shares outstanding has to be adjusted for the effects of all dilutive potential ordinary shares.

In accordance with IAS 33.33, net income is adjusted for the after tax effect of the interest of KEUR 33 and the transaction costs of KEUR 67 recognized for the convertible loan.

The weighted average number of shares used for the calculation of diluted earnings per share outstanding is without consideration of potential ordinary shares, because they do not lead to a dilution of equity.

	2004	2003
Net loss KEUR	-9,258	-6,317
Weighted number of shares	10,971,914	10,231,824
Non diluted earnings per share EUR	-0.8438	-0.6174
Diluted net loss KEUR	-9,158	-6,317
diluted earnings per share EUR	-0.8346	-0.6174

Fixed assets register

	Acquisition costs				Accumulated depreciation				Net book value	
	Jan 1, 04	Addition	Disposal	Dec 31, 04	Jan 1, 04	Addition	Disposal	Dec 31, 04	Dec 31, 04	Dec 31, 03
I. Tangible assets	7,554	542	-666	7,430	3,958	867	-556	4,269	3,161	3,596
II. Other intangible assets	2,878	397	-96	3,179	1,885	497	-54	2,328	851	993
III. Goodwill	29,749	0		29,749	5,860	3,000	0	8,860	20,889	23,889
IV. Financial assets	5,812	193	-8	5,997	1,455	440	0	1,895	4,102	4,357
1. Financial assets	4,118	0	0	4,118	1,455	440	0	1,895	2,223	2,663
2. Affiliated companies	1,561	193	0	1,754	0	0	0	0	1,754	1,561
3. Other	133	0	-8	125	0	0	0	0	125	133
V. Deferred taxes	10,459	0	-3,732	6,727	0	0	0	0	6,727	10,459
(all amounts in KEUR)	56,452	1,132	-4,502	53,082	13,158	4,804	-610	17,352	35,730	43,294

Notes to the balance sheet

Assets

Currents assets

12. Trade accounts receivable

Trade accounts receivable comprised in the group's individual companies include reasonable adjustments and generally have a remaining term of less than one year. A part of the receivables amounting to KEUR 3,011 is pledged for bank loans. The receivables are reduced by a specific allowance amounting to KEUR 559.

13. Inventories

This position predominantly contains purchased goods amounting to KEUR 3,162 (PY: 3,660), software licences amounting to KEUR 1,062 (PY: 1,083) and work in progress amounting to KEUR 267 (PY: 360). From the inventory, KEUR 531 is pledged for bank loans.

14. Other current assets

This position primarily comprises tax credits, loans and creditor receivables from pending reimbursements.

Non current assets

The development of the non current assets during fiscal year 2004 is indicated in the fixed assets register.

15. Goodwill

The impairment amounting to KEUR 3,000 applies to the goodwill of Euklid GmbH. In the financial year a product line not substantial for the M+M group was sold. The proceeds on disposal are contained in other income. Determined by the sale, the future cash flow surplus is reduced, whereby the recoverable amount falls under the book value of Euklid (cash generating unit). In the prior year, goodwill was regularly amortized by KEUR 1,390.

Individual goodwill development during the year under review was as follows:

Goodwill development			
Amounts in KEUR	Dec 31, 2003	Impairment	Dec 31, 2004
OPEN MIND	7,463		7,463
M+M UK	2,982		2,982
M+M Sweden	2,876		2,876
M+M Switzerland	1,265		1,265
DATAflor	1,135		1,135
COMPASS (AIM)	1,130		1,130
M+M Italy	1,116		1,116
ECS	711		711
M+M Akademie	700		700
EUKLID	3,623	-3,000	623
M+M Poland	474		474
M+M France	333		333
M+M Austria	81		81
Total	23,889	-3,000	20,889

16. Investments in affiliated companies

Since Jan 1, 2003, C-Plan AG, Muri near Bern, Switzerland, is consolidated at equity. In 2004 the increase of the book value is KEUR 193 (PY: 180). Intercompany profits and losses herewith have been insignificant. The variance between the prorated equity of the company and the net book value in the affiliated company amounts to KEUR 901, resulting predominantly from acquired goodwill.

17. Other investments

Other investments mainly include strategic shareholdings.

The following investments existed on December 31, 2004:

✘ Investments on Dec 31, 2004		
Amounts in KEUR	in %	Book value
YELLO! AG, Wiesbaden	29.3	427
CTB GmbH & Co KG, Buchholz	19.9	200
SOFISTiK AG, Munich	14.3	896
CYCO BV, Netherlands	7.4	700

M+M is performing current evaluations of the financial assets. For this purpose DCF models as well as industry-specific multipliers, which are multiplied by the shareholding's sustained gross margin are used to verify possible impairments. Actually twice the sustained annual gross margin is taken as the maximum book value of an investment not causing an impairment. According to this valuation scheme, a depreciation amounting to KEUR 440 for CYCO BV, Netherlands has been booked.

The maximum loss risk is the amount of the respective net book value plus loans given to shareholdings if applicable, amounting to KEUR 698 (PY: 958) as of Dec 31, 2004.

Liabilities**Current liabilities****18. Short term debt and current portion of long term debt**

This position almost exclusively contains bank loans at principal banks in Germany and abroad in the context of credit line. They are mainly secured by assignments of a claim, pledging of shares at technology subsidiaries as well as endorsements of members of the executive committee or the management of individual subsidiaries.

19. Accrued expenses

Accruals are calculated by taking all identifiable risks into account and always represent the expected repayment amount. They mainly include personnel and restructuring accruals. The development of the accruals in the reporting period is shown in the table of accrual development.

❖ Table of accrual development

Amounts in KEUR	Dec 31, 2003	Disposal	Addition	Dec 31, 2004
Personnel accruals	1,342	-1,342	1,132	1,132
Outstanding bills	745	-745	1,017	1,017
Restructuring accruals	434	-434	146	146
Other	680	-680	1.110	1.110
Total current accruals	3,201	-3,201	3,405	3,405
Personnel accruals	202	-49	0	153
Total non-current accruals	202	-49	0	153
Total accruals	3,403	-3,250	3,405	3,558

Table of accrual development

In the column disposal, there are no major reversings.

20. Other current liabilities

This position mainly includes debts from VAT and tax on wages and salaries, outstanding social security costs and deferred income.

Non-current liabilities

21. Long term debt, less current portion

This position contains the long term part of bank loans.

22. Convertible loan

As of July 15, 2004, 348,599 unregistered convertible loans have been issued with a nominal amount of EUR 1.00. The loans are issued at EUR 5.75 each.

The convertible loan has a running time of maximum four years and interest is paid annually with 5.75% of the issuing amount from July 15, 2004 (included) till July 14, 2008 if not paid back or converted. The interest is paid annually due on July 15 of the years 2005 to 2008. The loans are paid back latest July 14, 2008 if not paid back or converted before.

Each loan creditor has the right during the conversion window (one month after July 15, 2005, 2006, 2007 and last from June 1 to 30, 2008) to convert each loan held in the nominal amount of EUR 1.00 in 1 (one) ordinary share with a par value of EUR 1.00 of M+M AG. Therefore conversion rights could not be exercised yet.

M+M's CEO and principal shareholder Adi Drotleff signed the convertible loan amounting to KEUR 824.

The market value of the liability component and the equity component was determined as of the date of issuing of the loan. The market value of the liability component, which is contained in non current liabilities, was determined on the basis of a market interest rate of 9.0% for an appropriate straight loan. The remaining value of KEUR 211 (less transaction costs of KEUR 7), which represents the equity component, has been transferred to the capital reserve.

Consequently, the liability component will be measured at cost up to the conversion or maturity of the loan. However the equity component measured at the date of issuing of the loan remains unchanged. In the financial year, interest expenditures amounting to KEUR 53 were booked.

23. Pension accruals

The pension accruals essentially exist at the parent company and refer to a defined benefit plan for the management board. The pension commitment contains a retirement pay, a widow's pension as well as a disability pension. The pension accruals are determined according to actuarial principles of the projected unit credit method in accordance with IAS 19.

The pension accruals at the balance sheet date amount to KEUR 355 (PY: 276), of which an amount of KEUR 355 represents the determined cash value of the performance-oriented obligation not financed via funding. The cash value determined as at the balance sheet date of the performance-oriented obligations financed via funds amounts to KEUR 1.611. This figure also corresponds to the fair value of the plan assets as at the balance sheet date. The balance of actuarial profits and losses not yet included as at the balance sheet date amounts to non-reported profit of KEUR 640. The time of service expenditure to be calculated retrospectively and not yet reported in the balance sheet amounts to KEUR 0. The Statement of Income includes income from plan assets amounting to KEUR 166, interest expenses amounting to KEUR 96 and current time of service expenditure amounting to KEUR 51. The stated expenses and income are included in the general and administrative expenses.

In the financial year, pension has been paid in the amount of KEUR 39 to a former director of the Euklid GmbH.

The status of the defined benefit obligations is as follows:

	2004	2003
Benefit obligation at start of year	1,722	1,659
Interest cost	96	88
Benefits earned	51	43
Benefits paid	-39	-39
Net actuarial gain	136	-29
Benefit obligation at year end	1,966	1,722
Plan assets at start of year	1,445	1,375
Employer contributions	-39	-39
Actual return on plan assets	167	89
Net actuarial gain	38	21
Plan assets at year end	1,611	1,446
Net recognized liability	355	276

24. Other non current liabilities

This position contains an interest free shareholder loan of KEUR 1,500 (PY: 1,400) from CEO and principal shareholder Adi Drotleff.

Shareholders' equity

25. Share capital

As of June 24, 2004, a share split in the ratio of 1:2 was carried out and the subscribed capital per share has been set to EUR 1.00. Therefore the share capital has been increased by KEUR 3,960 from the capital reserve without issuing of new shares. Due to the capital increase performed at Dec 30, 2004, the subscribed capital increased by KEUR 1,058 out of the approved capital 2004 / I to KEUR 12,030 through the issuance of 1,058,000 new shares. The subscribed capital of M+M AG as of Dec 31, 2004 comprised 12,030,000 (PY: 5,485,957 before share split) shares, with a calculated stake of EUR 1.00 per share.

Following reconciliation shows the development of shares:

Shares as of Jan 1, 2004	5,485,957
Share split at Jun 24, 2004	5,485,957
	10,971,914
Capital increase	1,058,086
Shares as of Dec 31, 2004	12,030,000

26. Capital reserve

The capital reserve item primarily comprises the premiums from the 2004 capital increases amounting to KEUR 1,852 and the equity component of the convertible loan of KEUR 211. On the other side transaction costs net of tax in connection with the issuing of the convertible loan has been settled amounting to KEUR 54.

In the financial year an amount of KEUR 3,960 was transferred from the capital reserve to the share capital in the context of the settlement of the shares to the nominal amount of EUR 1.00 per share and the share split. In addition an amount of KEUR 24,236 was applied to balance out the retained earnings of the M+M AG according to § 150 Abs. 4 AktG.

Notes to the cash flow statement

27. Other information on operating activities

According to IAS 7.31 and 7.35, the following information on operating activities has to be disclosed: the total scope of interest settled in cash was KEUR 2,705 (PY: 2,509), interest received in cash was KEUR 78 (PY: 54). In addition, income taxes of KEUR 845 (PY: 400) were settled in cash.

The other expenses / income not using cash mainly contains of the change of the deferred taxes amounting to KEUR 3,746 (PY: -3,615) and the gain of a waiver from a bank loan amounting to KEUR -1,441 (PY: 0).

Other supplementary information

Other financial obligations and contingent liabilities

The other financial obligations resulting from rental and operating lease contracts for the group as a whole amounting to KEUR 11,051 (PY: 12,978).

In the current financial year rent and leasing payments are contained amounting to KEUR 3,411 (PY: 3,228).

The due dates of payments are as following:

	in KEUR
2005	2,559
2006	1,841
2007	1,515
2008	945
2009	858
following years	3,333
Total	11,051

Material leasing contracts mainly apply to office buildings at several locations, SAP software and company cars.

Additionally, there is a contingent liability as of April 1, 2007, from the OPEN MIND AG acquisition towards some of the old shareholders, which will be payable if the M+M share price should never achieve or exceed a level of EUR 15.25 per share for a period of at least four weeks until April 1, 2007. In this case an additional purchase price payment in cash amounting to the difference of the average M+M share price to EUR 15.25 in the 30 days prior to April 1, 2007, multiplied by 192,716 will be due. So the maximum additional payment (at a theoretical M+M share price of zero) thus would be $15.25 \times 192,716 = \text{KEUR } 2,939$.

Employees

The group's average number of employees (excluding temporary workers and trainees) during the fiscal year was 355 (PY: 405).

Management board

The management board of Mensch und Maschine Software AG, Wessling, was comprised of the following gentlemen:

Adi Drotleff, Diplom-Informatiker,
Schondorf (CEO)

Peter Baldauf, Diplom-Ingenieur (FH),
Wessling (Sales)

Michael Endres, Diplom-Informatiker (FH),
Fuerstenfeldbruck (Marketing)

Jens Jansen, Diplom-Ingenieur, MBA
München (CIO)

Peter Schuetzenberger, Kaufmann,
Hagenheim (CFO)

Werner Schwenkert, Diplom-Kaufmann,
Munich (CTO)

Advisory board

The advisory board of Mensch und Maschine Software AG, Wessling, was comprised of the following gentlemen:

Friedrich Soldner, Diplom-Kaufmann,
Retired tax consultant, Munich,
Chairman till Dec 31, 2004

Anton Sommer, Managing Director of
Sommer Equity Consulting GmbH,
Waltenhofen,
Vice Chairman till Aug 31, 2004

Thomas Becker, Diplom-Kaufmann,
Tax consultant, Neuss

Manfred Meinzer, Dipl.-Ingenieur (FH),
Managing Director of Executive Temporary
Management GmbH, Schwaebisch Gmuend,
Vice-Chairman from Sept 1, 2004 till
Feb 28, 2005

Günther Speiser, Bankbetriebswirt,
Consultant, Tamm,
Chairman from Jan 1, 2005

Norbert Kopp, Diplom-Ökonom,
Managing Director of KTB mbH & Co KG,
Hanover,
Vice Chairman from March 1, 2005

❖ Remuneration of management board members FY 2004

in KEUR	fixed	variable	non cash	Options
Adi Drotleff	158	0	70	0
Peter Baldauf	94	0	24	0
Michael Endres	91	0	26	0
Peter Schuetzenberger	105	0	26	0
Jens Jansen	94	0	29	0
Werner Schwenkert	102	0	11	0

Remuneration of board members

Remuneration for the management board amounted to KEUR 644 (PY 714), of which an amount of KEUR 0 (PY: 0) was variable. Additionally the members got non cash remuneration (e.g. company cars, pension commitments, life insurances) amounting to KEUR 186 (PY: 160). The management board was not granted share options during the period (PY: 66). The Black Scholes model was applied in assessing the fair value of the options.

Remuneration for the advisory board totalled KEUR 19 (PY: 20). This was split up into KEUR 10 for the Chairman and KEUR 5 for the member Mr. Becker and KEUR 4 for Mr. Sommer.

Mr. Meinzer received a remuneration of KEUR 70 during his advisory board activity according to a consultancy contract from March 2004. The advisory board has given the approval according to § 114 Abs. 1 AktG.

Directors' shareholdings and options

On Dec 31, 2004, the members of the management board owned 6,096,296 shares (PY: 6,096,296) and 138,000 options (PY: 142,800) in Mensch und Maschine Software AG. Stock ownership of the members of the advisory board as of Dec 31, 2004, was 4,000 shares (PY: 3,400), the option ownership of the members of the advisory board was 0 (PY: 0).

Stock and option ownership of individual members of the boards as per Dec 31, 2004, is shown in the following table:

❖ Directors' holdings Dec 31, 2004		
<i>Management Board</i>	Shares	Options
Adi Drotleff	5,181,908	168,853
Peter Baldauf	20,444	26,800
Michael Endres	24,000	26,800
Jens Jansen	19,944	21,200
Peter Schuetzenberger	30,000	26,800
Werner Schwenkert	820,000	10,800
<i>Supervisory Board</i>		
Friedrich Soldner	4,000	0
Anton Sommer	1,000	0
Thomas Becker	0	0
Manfred Meinzer	0	0

Other advisory board memberships of board members

On December 31, 2004, Mr. Sommer also served as chairman of the advisory board for Saechsisches Druck- und Verlagshaus AG, Dresden.

On December 31, 2004, Mr. Becker also served as a member of the advisory board for DATAflor AG, Goettingen.

On December 31, 2004, Mr. Meinzer also served as chairman of the advisory board for INOVA AG, Planegg.

On December 31, 2004, Mr. Drotleff also served as chairman of the advisory board of DATAflor AG, Goettingen, and further was a member of the advisory board for SOFiSTIK AG, Munich.

On December 31, 2004, Mr. Baldauf was also a member of the advisory board of YELLO! AG, Wiesbaden and of Verwaltungsrat of C-Plan AG, Muri, Switzerland.

On December 31, 2004, Mr. Kopp also served as a member of the advisory board of KIH Kunersdorf Immobilien Holding AG, Hanover, of Foris AG, Bonn, of WAS World Wide Analytical Systems AG, Uedem, of HNE Technologie AG, Augsburg, as well as ComHouse AG, Wuerzburg.

The remaining board members had no seats on any other advisory boards.

**Declaration in accordance to §161 AktG
(German Corporate Governance Codex)**

The company has published for 2004 the declaration required in accordance with §161 AktG and made it accessible to its shareholders via the internet (www.mum.de).

Release date for publishing

The consolidated financial statement of Mensch und Maschine AG was released for publishing on April 29, 2005. Publishing was approved by the advisory board. The date of publishing was April 29, 2005.

Events after balance sheet date

As of February 16, 2005, all remaining shares of Compass systems GmbH have been purchased and the merger with M+M AG has been filed to the commercial register. The commercial registration did not take place yet. With the asset purchase agreement as of February 17, 2005, all assets and liabilities of the subsidiary Compass systems GmbH merged to M+M AG have been sold. The closing of this transaction is intended at the end of March, after the commercial registration of the merger in the commercial register, and will lead to a cash inflow of approximately KEUR 7,000 and a net book profit of approximately KEUR 3,000.



❏ CAD in practice

Designing with Pro/ENGINEER Wildfire from PTC

Project: Shortening design cycles for industry gyroscope pumps

Customer: FAPMO SA, Outreau, France

FAPMO specialises in industry gyroscope pumps, supplying various industries including: marine, desalting plants, iron foundries, energy production, mining, chemical and food. These pumps contain complex curved forms, which were insufficiently supported by most of the CAD systems previously tested. Pro/ENGINEER Wildfire enables the design and combination of continuous complex curves without manual corrections, significantly shortening the design cycle for new products and modules at FAPMO.

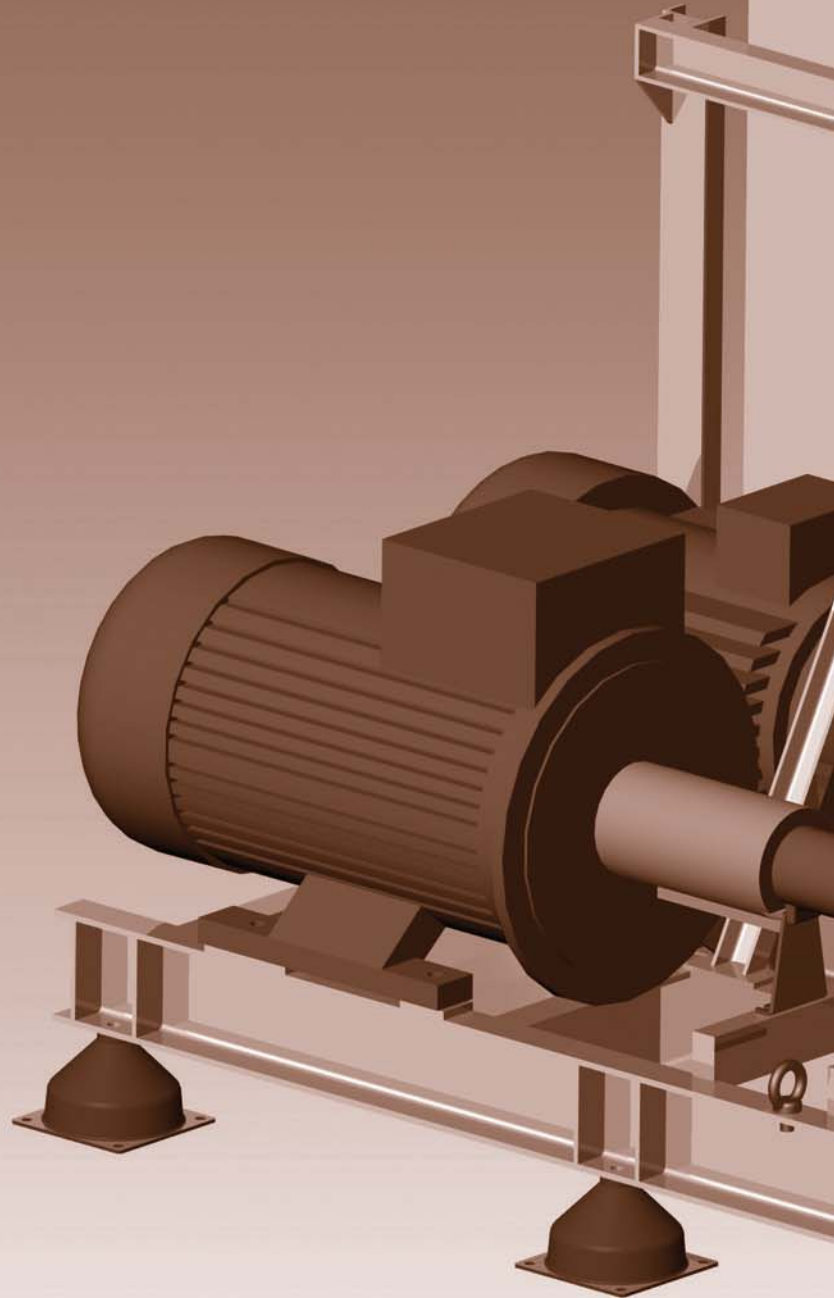

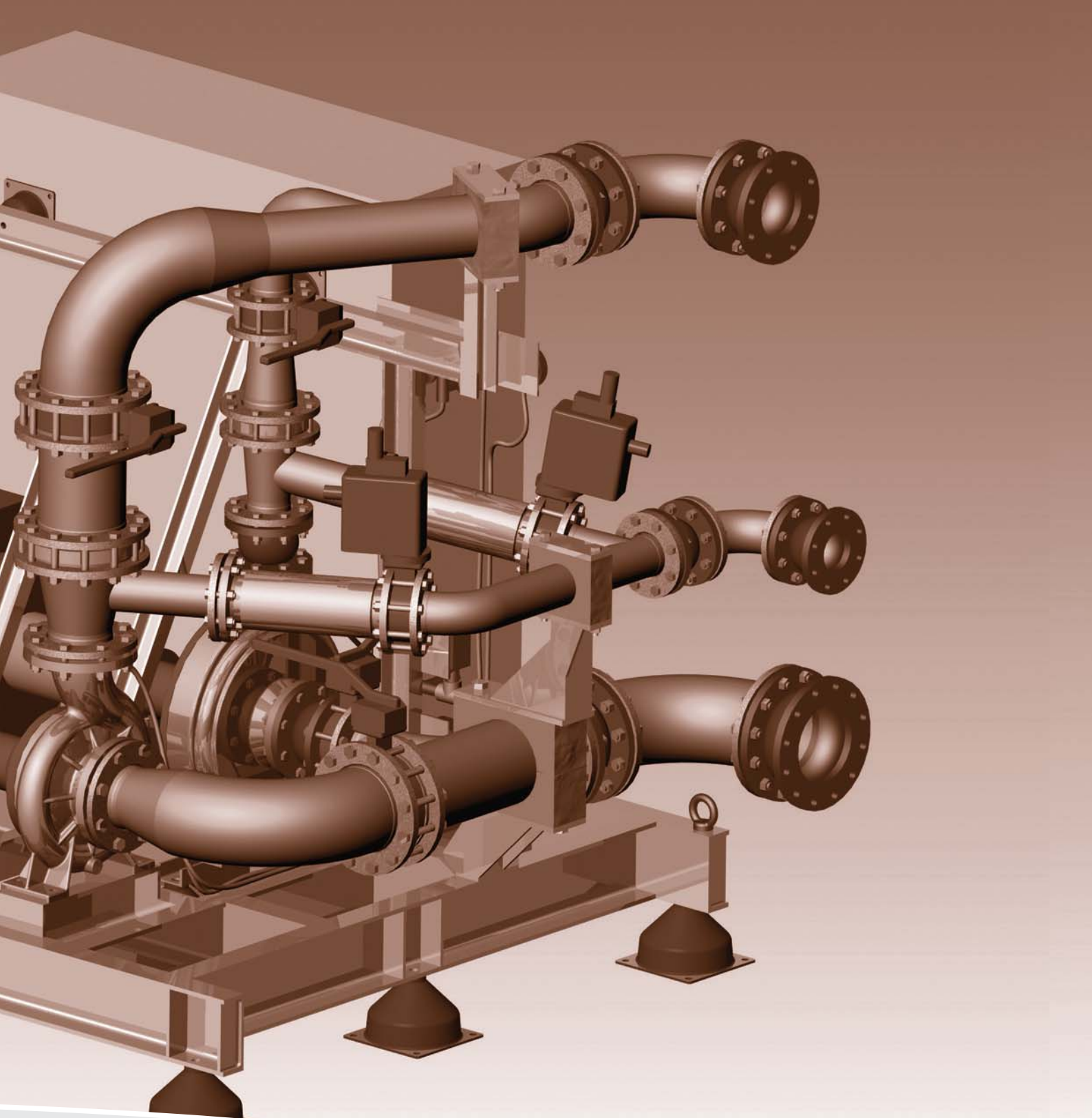

Advisory Board Report

During the year under review, the Advisory Board of Mensch und Maschine Software AG, Wessling, fulfilled all its obligations as incumbent, pursuant to the corresponding statutes and by-laws, and including the ongoing supervision of the company management. During fiscal year 2004, five joint board meetings took place on March 17, March 26, May 24, July 20 and November 11, 2004. Additionally, outside the setting of the official meetings, there were discussions between Management and Advisory Board on company policy and business development. There were no additional Advisory Board committees.

Outside the official meetings management consulted the Advisory Board in all important matters of the company. The Advisory Board shared these decisions within the scope of its obligations.

Advisory and Management Board explicitly committed to the recommendations for responsible corporate governance fixed in the German Corporate Governance Codex and voluntarily committed to actions exceeding the codex.

The annual report of Mensch und Maschine Software AG as of December 31, 2004 including the management report, as well as the group annual report as of December 31, 2004 including the management report for

the group was set up by the Management Board and audited by Ernst & Young AG Wirtschaftsprüfungsgesellschaft (auditing firm), Munich, and endorsed with an unqualified audit opinion. The Advisory Board also reviewed the Management Board's set up which, together with the auditing reports from the auditing firm was available to all members of the Advisory Board. The auditor took part in the annual fiscal year report meetings on March 3 and 18, 2005, and reported upon all significant results of the audit. The Advisory Board finally agrees to the annual report and group annual report, raising no objections after its own review.

The Advisory Board approves the annual report and group annual report, both set up by the Management Board. The annual report thus is adopted in accordance with §172 AktG.

The dedication and commitment displayed by management and employees again contributed fundamentally to the company's commercial success during fiscal year 2004. The Advisory Board would like to take this opportunity to acknowledge its gratitude and appreciation for the exemplary performance demonstrated by all company employees.

Wessling, April 2005
The Advisory Board

Guenther Speiser
Chairman

Auditors' Report

"We have audited the consolidated financial statements, comprising the balance sheet, statement of operations, statement of changes in stockholders' equity and statement of cash flows and segment reporting, as well as the notes to the consolidated financial statements, prepared by Mensch und Maschine AG, Wessling, for the business year from January 1 to December 31, 2004. The preparation and the content of the consolidated financial statements are the responsibility of the Company's executive board. Our responsibility is to express an opinion whether the consolidated financial statements are in accordance with International Financial Reporting Standards (IFRS) based on our audit.

We conducted our audit of the consolidated financial statements in accordance with German auditing regulations and generally accepted standards for the audit of financial statements promulgated by the Institut der Wirtschaftsprüfer (IDW). Those standards require that we plan and perform the audit such that it can be assessed with reasonable assurance whether the consolidated financial statements are free of material misstatements.

Knowledge of the business activities and the economic and legal environment of the Company and evaluations of possible misstatements are taken into account in the determination of audit procedures. The evidence supporting the amounts and disclosures in the consolidated financial statements are examined on a test basis within the framework of the audit. The audit includes assessing the accounting principles used and significant estimates made by management and Company's executive board, as well as evaluating the overall presentation of the consolidated financial statements.

We believe that our audit provides reasonable basis for our opinion.

In our opinion, the consolidated financial statements give a true and fair view of the net assets, financial position, results of operations and cash flows of the Group for the business year in accordance with IFRS. Our audit, which also extends to the Group's management report prepared by the executive board, for the business year from January 1 to December 31, 2004, has not led to any reservations. In our opinion, on the whole the Group's management report together with the other disclosures in the consolidated financial statements provides a suitable understanding of the Group's position and suitably presents the risks of future development.

In addition, we confirm that the consolidated financial statements and the Group's management report for the business year from January 1 to December 31, 2004 satisfy the conditions required for the Company's exemption from its obligation to prepare consolidated financial statements and the Group's management report in accordance with German law.

Without qualifying this opinion, we refer to the comments in the management report. Section "Risks - Financing Risks" of the management report state that a failure of the third party financing is not impossible. This would cause serious problems regarding the Group's solvency and the Group's future development. Even with a tight liquidity, the Group's management is convinced that the liquidity can be improved to a comfortable level based on the existing liquidity budget during the year 2005."

Munich, March 18, 2005

Ernst & Young AG
Wirtschaftsprüfungsgesellschaft

J. Zapf
Wirtschaftsprüfer

D. Gallowsky
Wirtschaftsprüfer

- **Mensch und Maschine Software AG**
 Argelsrieder Feld 5
 82234 Wessling
 Phone +49 (0) 81 53 / 9 33 - 0
 Telefax +49 (0) 81 53 / 9 33 - 100
 Infoline: 01 80 / 56 86 - 4 61 (EUR 0,12/min.)
www.mum.de
 Schinkestrasse 8 / 9
 12047 Berlin
 Phone +49 (0) 30 / 6 93 30 72
 Telefax +49 (0) 30 / 6 91 50 18
 Niederkasseler Lohweg 20
 40547 Duesseldorf
 Phone +49 (0) 211 / 5 27 40 - 100
 Telefax +49 (0) 211 / 5 27 40 - 109
 Luisenplatz 1
 65185 Wiesbaden
 Phone +49 (0) 6 11 / 99 99 30
 Telefax +49 (0) 6 11 / 37 88 08
- **Mensch und Maschine Austria**
 Alpenstrasse 48A
 5020 Salzburg
 Phone +43 (0) 6 62 / 62 61 50
 Telefax +43 (0) 6 62 / 62 61 50 10
www.mum.at
- **Mensch und Maschine Switzerland**
 Opfikonerstrasse 45
 8304 Wallisellen
 Phone +41 (0) 8 48 / 10 00 01
 Telefax +41 (0) 1 / 883 74 74
www.mum.ch
 Route de saint Légier 7
 1800 Vevey
 Phone +41 (0) 8 48 / 10 00 01
 Telefax +41 (0) 21 / 793 20 39
- **Man and Machine France**
 88, av. du Général de Gaulle
 93170 Bagnolet
 Phone +33 (0)1 / 55 82 45 82
 Telefax +33 (0)1 / 55 82 45 50
www.manandmachine.fr
- **Man and Machine UK**
 Unit 8 Thame 40
 Jane Morbey Road
 Thame, Oxfordshire, OX9 3RR
 Phone +44 (0) 18 44 / 26 18 72
 Telefax +44 (0) 18 44 / 21 67 37
www.manandmachine.co.uk
- **Man and Machine Italy**
 Via Torri Bianche, 7
 20059 Vimercate (MI)
 Phone +39 / 039 / 69 994 1
 Telefax +39 / 039 / 69 994 44
www.mum.it
- **Man and Machine Sweden**
 Prästgårdsgatan 1, 12tr
 172 32 Sundbyberg
 Phone +46(0) 8 / 4 75 42 00
 Telefax +46(0) 8 / 4 75 42 99
www.manandmachine.se
- **Man and Machine Poland**
 Zeromskiego Str. 52
 90-626 Lodz
 Phone +48 (0) 42 / 6 39 23 - 70
 Telefax +48 (0) 42 / 6 39 23 - 79
www.mum.pl
- **Man and Machine Benelux**
 Assesteenweg 25-29
 1740 Ternat
 Phone +32 (0) 2 / 5 83 16 00
 Telefax +32 (0) 2 / 5 82 12 82
www.manandmachine.be
 Veldbeemdgras 58
 8043 KE ZWOLLE
 Phone +31 (0) 38 / 4 20 42 84
 Telefax +31 (0) 38 / 4 20 42 85

- **DATAflor Software AG**
 August-Spindler-Strasse 20
 37079 Goettingen
 Phone +49 (0) 551 / 5 06 65 - 50
 Telefax +49 (0) 551 / 5 06 65 - 59
www.dataflor.de

Gustav-Freytag-Strasse 12
 01277 Dresden
 Phone +49 (0) 3 51 / 3 15 66 - 0
 Telefax +49 (0) 3 51 / 3 15 66 - 59

Poststrasse 13a
 14979 Berlin / Grossbeeren
 Phone +49 (0) 3 37 01 / 5 26 - 0
 Telefax +49 (0) 3 37 01 / 5 26 - 59

Rheinstrasse 150
 46562 Voerde
 Phone +49 (0) 28 55 / 96 14 72
 Telefax +49 (0) 28 55 / 96 14 76

Friedrich-Naumann-Strasse 33
 76187 Karlsruhe
 Phone +49 (0) 7 21 / 94 46 8 - 0
 Telefax +49 (0) 7 21 / 94 46 8 - 59
- **ECS GmbH**
 Oeschstrasse 33
 73072 Donzdorf
 Phone +49 (0) 71 62 / 92 93 70
 Telefax +49 (0) 71 62 / 2 42 00
www.ecscad.de
- **EUKLID Software GmbH**
 Argelsrieder Feld 5
 82234 Wessling
 Phone +49 (0) 81 53 / 9 33 - 0
 Telefax +49 (0) 81 53 / 9 33 - 100
www.euklid-software.de

Schinkestrasse 8 / 9
 12047 Berlin
 Phone +49 (0) 30 / 69 59 32 20
 Telefax +49 (0) 30 / 6 91 50 18

Niederkasseler Lohweg 20
 40547 Duesseldorf
 Phone +49 (0) 211 / 5 27 40 - 0
 Telefax +49 (0) 211 / 5 27 40 - 280

Carl-Zeiss-Strasse 17
 73230 Kirchheim/Teck
 Phone +49 (0) 70 21 / 5 09 89 70
 Telefax +49 (0) 70 21 / 5 09 89 71
- **Mensch und Maschine Akademie GmbH**
 Badstrasse 62
 73087 Bad Boll
 Phone +49 (0) 71 64 / 9 31 - 01
 Telefax +49 (0) 71 64 / 9 31 - 299
www.mumakademie.de
- **OPEN MIND Technologies AG**
 Argelsrieder Feld 5
 82234 Wessling
 Phone +49 (0) 81 53 / 93 35 00
 Telefax +49 (0) 81 53 / 93 35 01
www.openmind-tech.com

Carl-Zeiss-Strasse 17
 73230 Kirchheim/Teck
 Phone +49 (0) 70 21 / 95 95 05
 Telefax +49 (0) 70 21 / 95 95 04

Niederkasseler Lohweg 20
 40547 Duesseldorf
 Phone +49 (0) 211 / 5 27 40 - 300
 Telefax +49 (0) 211 / 5 27 40 - 309

Blumenstrasse 6
 74358 Pleidelsheim
 Phone +49 (0) 71 44 / 88 67 0
 Telefax +49 (0) 71 44 / 88 67 15
- **OPEN MIND Technologies UK Ltd.**
 Unit 8 Thame 40
 Jane Morbey Road
 Thame, Oxfordshire, OX9 3RR
 Phone +44 (0) 1844 / 26 37 39
 Telefax +44 (0) 1844 / 21 67 37
www.openmind-tech.com
- **OPEN MIND Technologies Italia S.r.l.**
 Via Pomè 14
 20017 Rho (MI)
 Phone +39 / 02 / 93 16 25 03
 Telefax +39 / 02 / 93 18 44 29
www.openmind-tech.com
- **OPEN MIND Software Technologies S.a.r.l.**
 Savoie Technolac Bp 325
 73377 Le Bourget du Lac Cedex
 Phone +33 (0)4 / 79 26 46 22
 Telefax +33 (0)4 / 79 26 46 24
www.openmind-tech.com
- **OPEN MIND Software Technologies USA, Inc.**
 70 Walnut Street
 Wellesley Hills, MA 02481
 Phone +1 (781) 239 80 95
 Telefax +1 (270) 912 58 22
www.openmind-tech.com

39111 W.Six Mile Rd.
 Livonia Detroit, Michigan 48152
 Phone +1 (734) 779 16 25
 Telefax +1 (734) 779 16 26
- **OPEN MIND Technologies Asia Pacific Pte Ltd.**
 10 Ubi Crescent # 05-22, Ubi Techpark
 Singapore 408564
 Phone +65 67 42 95 56
 Telefax +65 67 42 95 26
www.openmind-tech.com
- **OPEN MIND Software Technologies Japan Inc.**
 KS Building 1006, 1-31-11, Kichijojihoncho
 Musashino-shi, Tokyo 180-0004
 Phone +81 422 23 - 53 05
 Telefax +81 422 23 - 53 05
www.openmind-tech.com

Investor contact	
Contact person	Michael Endres
Phone	+49(0)8153 / 933 - 261
Telefax	+49(0)8153 / 933 - 104
E-Mail	investor-relations@mum.de
Internet	www.mum.de/investor

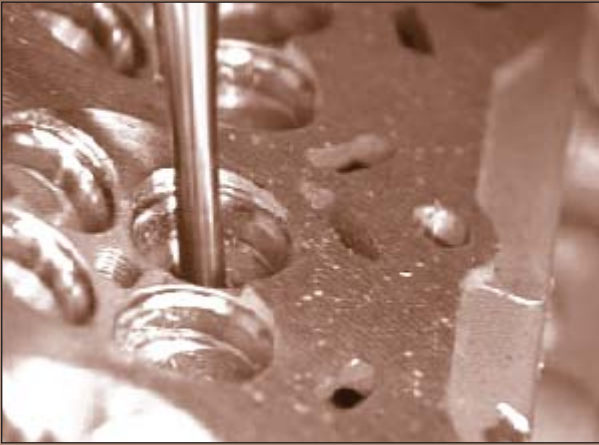

CAM in practice: Automotive industry

Project: Prototyping of an engine block

Customer: Renowned automotive manufacturer

Among other details, the shape of cylinder heads significantly impact the efficiency and power of an engine. Though the airflow can be calculated with the aid of special software, practical tests are essential for optimization. To mill the prototypes needed for this purpose, quickly and cost effectively, engine manufacturers around the world are using CAM (Computer Aided Manufacturing) software from M+M group member OPEN MIND.

OPEN MIND's hyperMILL product family simplifies the programming of the milling process, reducing development time, and time to market significantly. Furthermore, the new milling and machining simulation offers maximum process security to the manufacturing engineer.

menschen  **maschine**
CAD as CAD can

**Mensch und Maschine
Software AG**

Argelsrieder Feld 5
D-82234 Wessling

Phone +49 (0) 81 53 / 9 33 - 0
Fax +49 (0) 81 53 / 9 33 - 100
www.mum.de

